

LEVEL SWITCH NP-2T DL v1.0

Installation instructions

Order no. 13180



Description

The NP-2T DL level switch is intended for **dynamic lighting control** using dimmable light fittings with digital DALI control, in order to reduce the lighting time of fluorescent light sources and prolong their life. It is used in combination with one or more presence detectors (e.g. PD-2200) in areas such as **corridors, stairways and garages**.

See the application examples in this manual, in the Planning Guide in the Energy-saving Detection Technology manual and at www.extronic.se, (see also applications for NV-2T).

Dynamic lighting control

Dynamic lighting control means that the power output (lighting level) is adjusted to the normal lighting level (often 80 per cent) when presence is detected in the premises. When presence is no longer detected the lighting is reduced to the base level (the lowest possible level, often 1–2 per cent).

If someone enters the premises again the lighting is ramped up to the normal level.

If the premises remain empty until the timer in NP-2T DL has counted down (recommended setting 1–2 hours), the lighting is switched off completely.

The reason why the lighting is not switched off as soon as the premises are empty is that frequent switching causes accelerated wear to the fluorescent tubes and shortens their lives. If LED light fittings are installed, this feature can be used to provide background lighting or ambient lighting.

Basic operation

- When someone enters the premises the lighting is switched on at the normal level (High level) when presence is detected by the presence detector.
- When presence is no longer detected the lighting is switched to the base level (Low level) and the timer starts counting down the preset time (0–120 minutes).
- When this time has run out the lighting is switched off completely.

If someone enters the premises while the timer is counting down, the lighting is switched from the base level to the normal level, and the timer restarts the countdown when presence is no longer detected. If someone enters the premises when the lighting has been switched off completely, it is immediately switched back on at the normal level.

Features

- Controls DALI light fittings using broadcast commands.
- No programming is required.
- Built-in power supply for DALI bus.
- Supply voltage 230 VAC.
- Add Detector Time. Allows detector delay time to be set in addition to time in detector.
- SoftDim allows the lighting to be ramped up and down gradually. The ramp-up rate is adjustable, but the dimming rate is fixed.
- Fluorescent tube burn-in. A button that delivers 100 per cent power for 100 hours to burn in new tubes.

Inputs and outputs

- Output for DALI light fittings.
- Input for presence detector or logic module.
- Blocking input. If a light sensor is connected it can prevent the lighting from being switched on when there is sufficient natural light.
- Pushbutton input. If one or more pushbuttons are connected (in parallel) the lighting can be switched on or off and ramped up or down manually.
- Relay output for driving a contactor with adjustable timer (0–120 minutes).
- 12 VDC supply for IR detectors (max. 8 detectors).

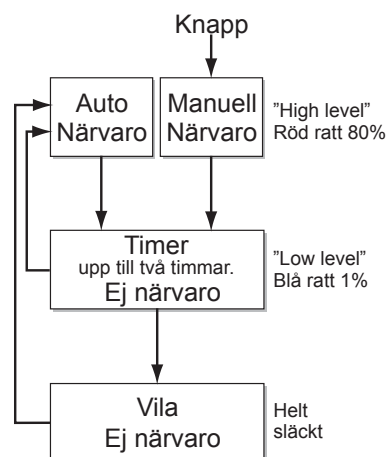
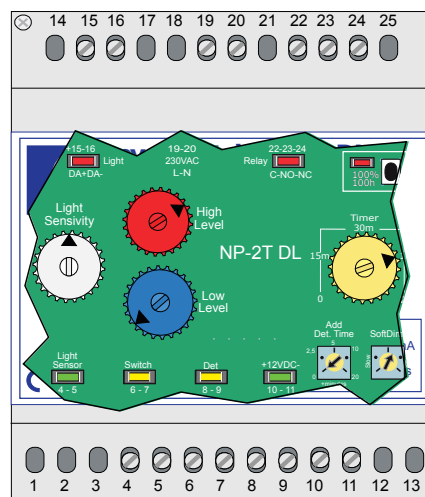

Features, connections and settings

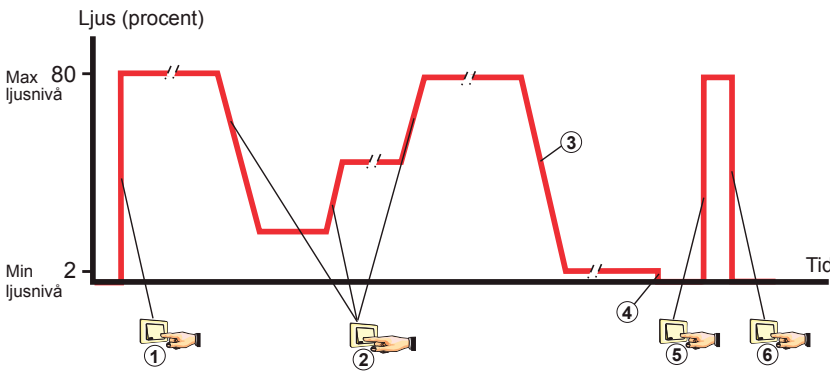
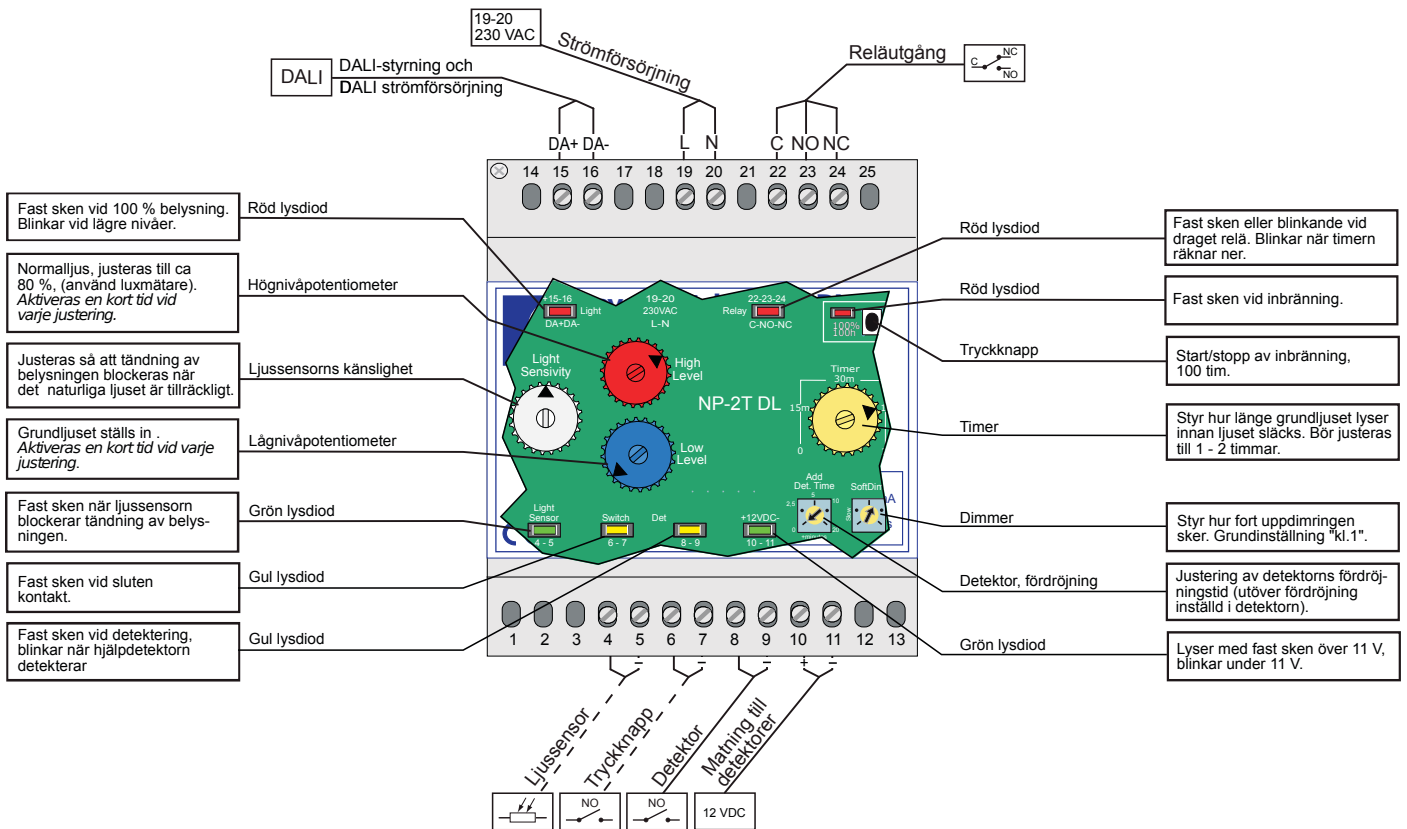

- ① Kort tryck ger direkt tändning till max-ljusnivån.
- ② Med långt tryck kan belysningen dimmas upp och ner.
- ③ Automatiskt dimning ner till min-nivån när detekteringen av närvaron upphör.
- ④ Belysningen släcks helt efter inställd tid (1 - 2 timmar).
- ⑤ Kort tryck tänds belysningen till max-nivån.
- ⑥ Kort tryck släcker belysningen helt.

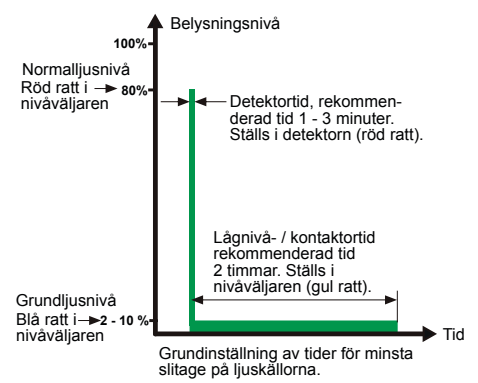

Application examples

A. Premises without natural light

Premises without natural light, with automatic on/off switching.

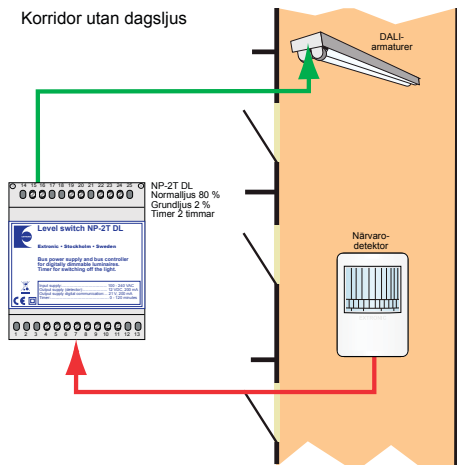

B. Premises with natural light

Premises with automatic on/off switching and pushbuttons for manual on/off switching and dimming. A light sensor prevents the lighting from being switched on when there is sufficient natural light.

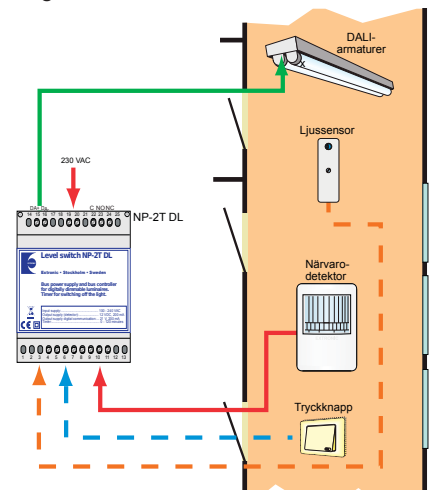

Wiring

NP-2T DL is easily installed on a DIN rack in a standard enclosure. Underneath the label is a cover that can be opened by lifting the bottom edge. Underneath the cover are indicator LEDs for the inputs, outputs and adjustment potentiometers.

Terminals 4–5, light sensor

The LS-10 light sensor is installed in a location where it will be exposed to daylight, in a window recess for example. Connect the light sensor to terminals 4 and 5.

The Start Block LED (green) glows steadily when there is sufficient natural light, preventing the lighting from being switched on automatically.

NOTE! See section on Commissioning for instructions on adjusting the light sensor.

Terminals 6–7, pushbuttons

One or more spring-loaded momentary pushbuttons can be connected between terminals 6 and 7.

A closing pulse switches the lighting on or off. If more than one pushbutton is installed they must be connected in parallel.

If a pushbutton is held in, the lighting can be ramped up and down between the one-per-cent level and the normal level (High level). The Switch LED (yellow) glows steadily when a switch is closed.



Special configurations for pushbutton input:

Ramping up to 100 per cent

If a 1.5 kΩ resistor is connected in series, the lighting can be ramped all the way up to 100 per cent even if the Max light level potentiometer (red) is set to a lower value.

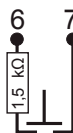

Switching on only

If a 4.7 kΩ resistor is connected in series, the lighting can only be switched on. A single press provides 15 minutes of lighting time without the need for presence to be detected.



Latching switch

If a 10 kΩ resistor is connected in series a switch with latching contacts can be used to switch lighting on and off.

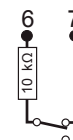

Overriding digital off pulse

If a 22 kΩ resistor is connected in parallel, it prevents the sending of digital off pulses. The relay still opens, however.



Terminals 8–9, detector

One or more presence detectors (normally open contacts) are connected so that they short-circuit terminals 8 and 9 when presence is detected. The Det. LED (yellow) glows steadily when presence is detected and flashes when an auxiliary detector detects presence.



Special configurations for detector input:

Detectors that cannot switch lighting on

If a 4.7 kΩ resistor is connected in series it is possible to connect detectors that are not intended to switch the lighting on, such as an AD-350 auxiliary detector. This is connected in parallel with the main detector. This resistor can also be added if the lighting is not to be switched on automatically.

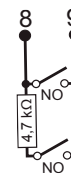

NC input for normally closed detector

If a 22 kΩ resistor is connected in series with a normally closed magnetic switch in a door, for example, the lighting can be switched on before presence is detected by the presence detector. The magnetic switch (NC) is connected in parallel with the detector and a 22 kΩ resistor is connected in series with the magnetic switch.

The fixed delay time is two minutes.

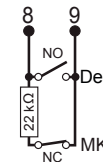

Extended operation

If a 10 kΩ resistor is connected between terminals 8 and 9 it activates extended operation.

See the section on Extended Operation for more information.

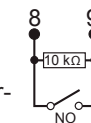

Terminals +10 -11, supply to detectors

12 VDC supply for IR detectors. Up to eight PD-2200 detectors can be supplied with power.

Terminals +15 -16, DALI

Output for digital control of DALI light fittings and for driving DALI bus.

The Light LED indicates the lighting power. When it glows steadily the lighting is at maximum brightness, and when it is dark the lighting is switched off. Between these two states, the LED flashes and the length of the pulse indicates the lighting level.

If the supply voltage to NP-2T DL is interrupted the light fittings will be switched to maximum brightness (unless the light fittings are programmed otherwise).

Terminals 19–20, 230 VAC

For connecting 230 VAC supply voltage.

Terminals 22-23-24, relay output

Relay output C-NO-NC.

C (22) is the common terminal for the internal relay.

When the lighting is to be switched on there should be continuity between C and NO.

If NP-2T DL loses its supply voltage, the relay closes and makes contact between C and NO so that the lighting is switched on.

The C-NO-NC LED (red) glows steadily when the relay is closed and flashes when the timer is counting down. When the LED is off the relay is not closed.

See wiring examples on following page!

Wiring example with PD-2200 IR detector

The example shows a corridor with manual lighting control

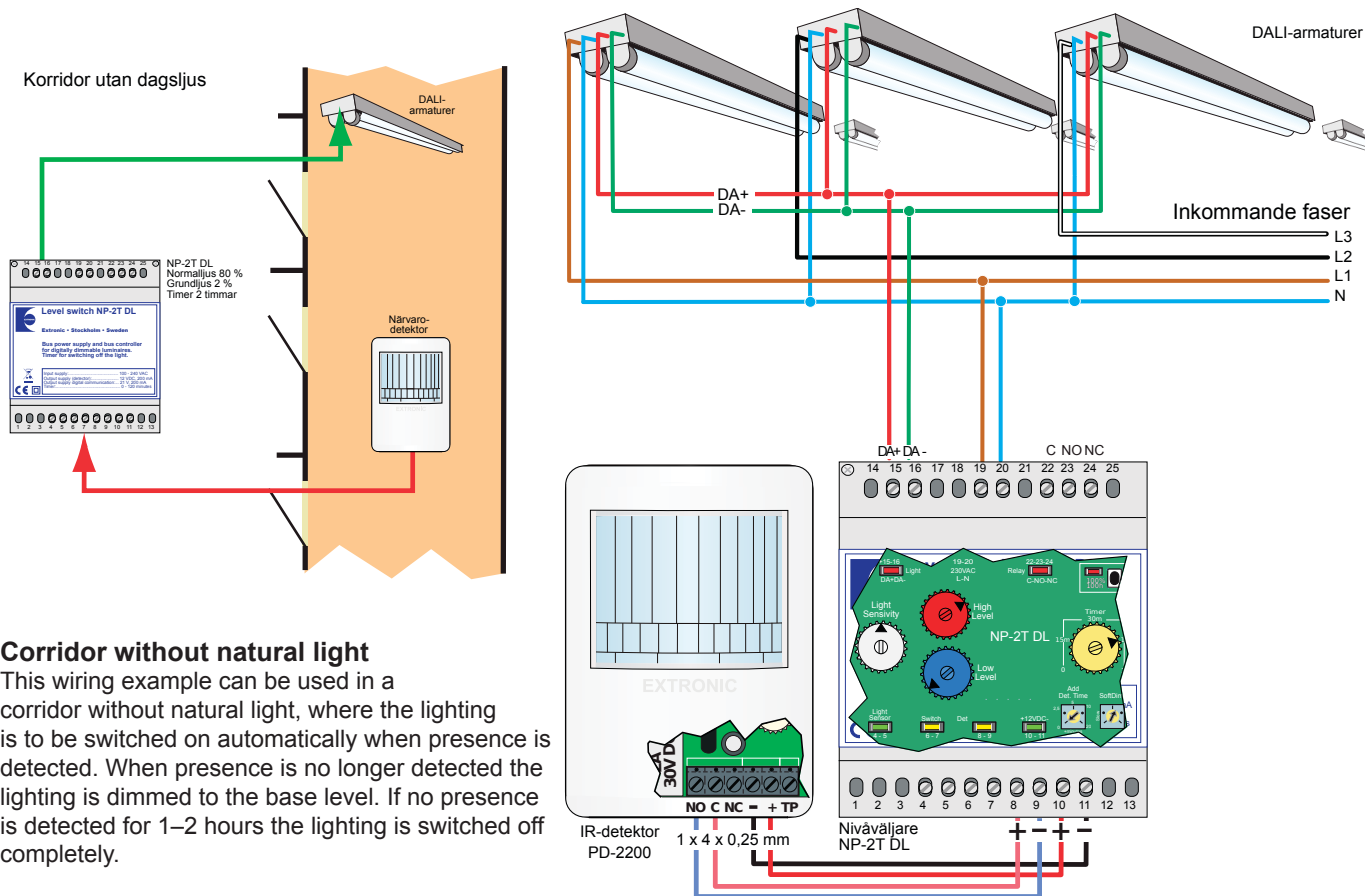

Corridor without natural light

This wiring example can be used in a corridor without natural light, where the lighting is to be switched on automatically when presence is detected. When presence is no longer detected the lighting is dimmed to the base level. If no presence is detected for 1–2 hours the lighting is switched off completely.

Wiring example with AD-600 acoustic detector with SoftDim feature for ramping lighting up and down gently

Stairway with natural light

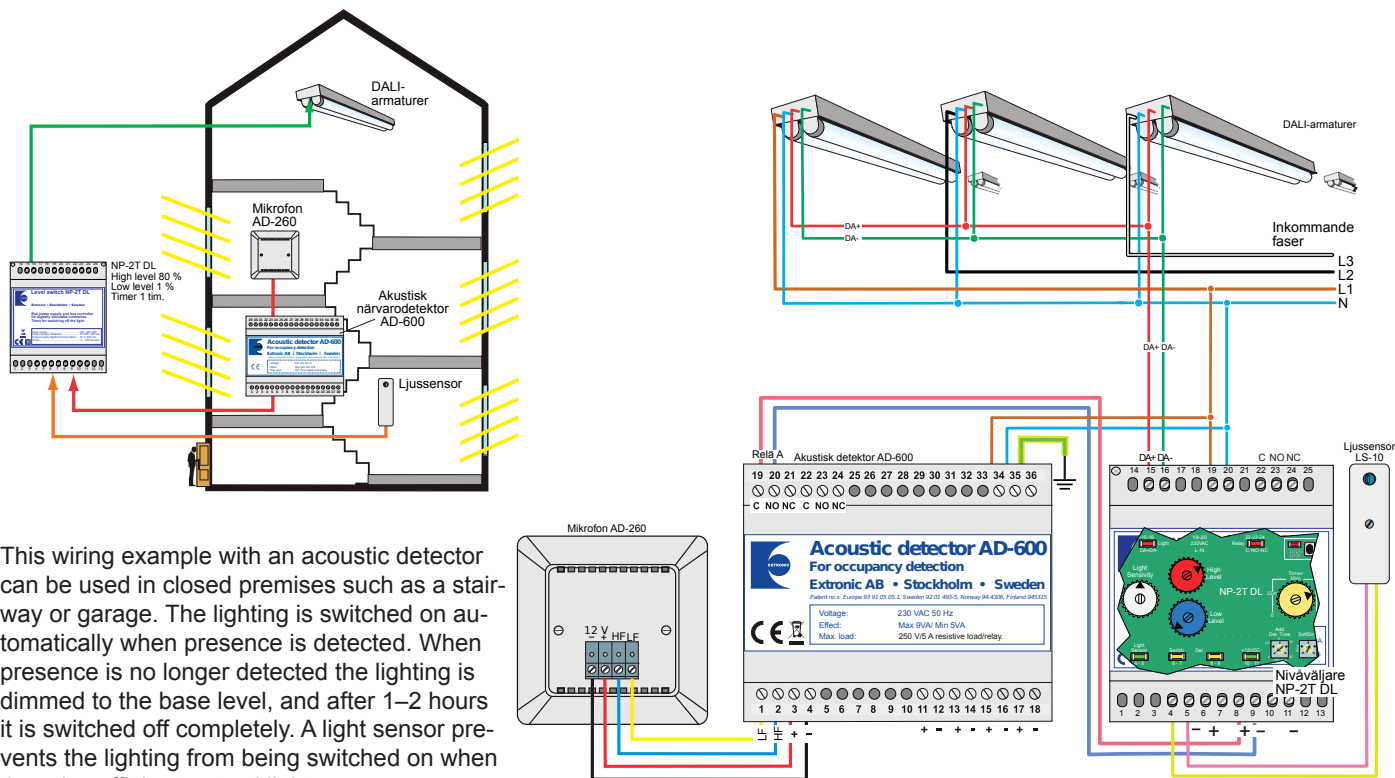

This wiring example with an acoustic detector can be used in closed premises such as a stairway or garage. The lighting is switched on automatically when presence is detected. When presence is no longer detected the lighting is dimmed to the base level, and after 1–2 hours it is switched off completely. A light sensor prevents the lighting from being switched on when there is sufficient natural light.

See the section on Commissioning for information on adjusting the light sensor.

Wiring example with PD-2200 IR detector

The example is a dining hall with manual control of lighting.

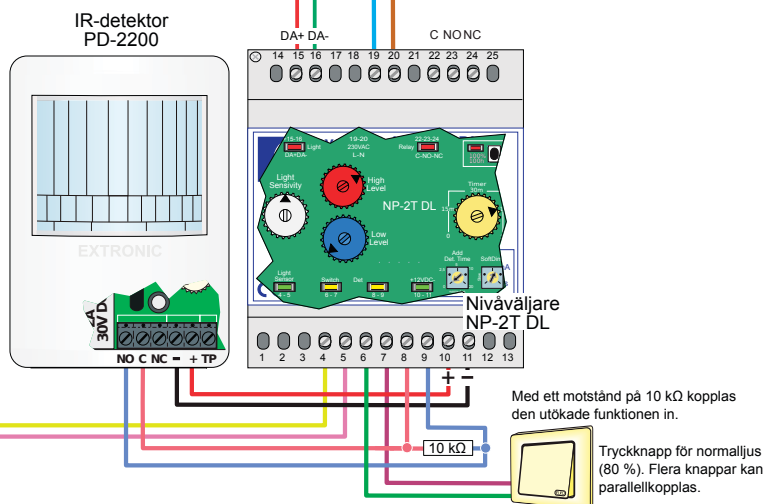
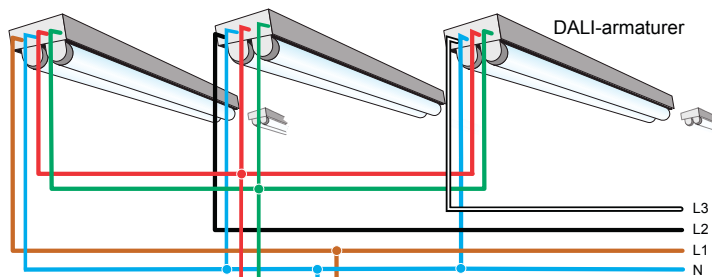
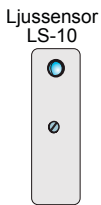
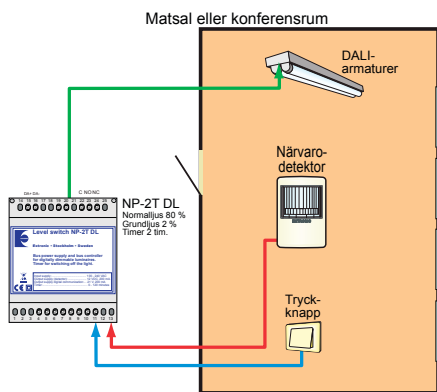

The lighting is never switched on automatically if a jumper is placed between terminals 4 and 5 (blocking input).

This wiring example is intended for a dining hall with dimmable light fittings with DALI control, but can also be used for other similar premises.

The lighting must always be switched on manually using a pushbutton and comes on at the normal level, which is about 80 per cent of the High level (red).

When everyone has left the premises the lighting is automatically reduced to the base level (Low level) and is switched off completely after 1–2 hours. The time is set using the Timer potentiometer (yellow).

Wiring example for stairway without detector Automated stairway lighting for dimmable DALI light fittings

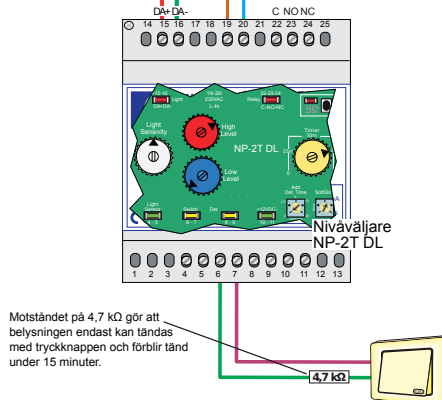
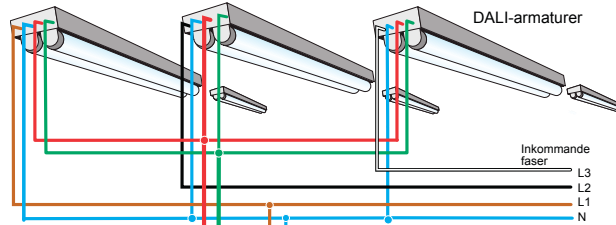
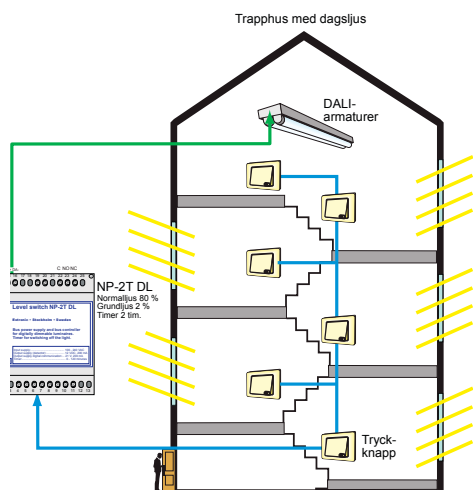

This wiring example is intended for a stairway with dimmable light fittings with DALI control. The lighting is switched on manually at the normal level, around 80 per cent of the High level (red), by means of pushbuttons.

After 15 minutes the lighting is reduced to the Low level (blue), which is recommended to be set at around 20–30 per cent.

If presence is not detected for an extended period the lighting is switched off entirely. This time can be adjusted between 0–2 hours with the Timer potentiometer (yellow). This time should be set to be as long as possible, ideally 1–2 hours.

This is a low-budget solution for controlling dimmable light fittings (DALI). Most people who use the stairway do not press the button to increase the lighting to the level required by Swedish standards. The lower lighting level is adequate for them to find their way, which saves energy.

See application 4B in the Energy-saving Detection Technology handbook or at www.extronic.se for a recommended solution using dimmable light fittings.

Extended operation

Extended operation is similar to normal operation, but with the **base level lighting fixed at 1 per cent**. The Low level and High level (red) potentiometers now have different functions:

- The lower level, which is switched on automatically, is set using the Low level (blue) potentiometer, (recommended as 30 per cent).
- The higher level, which is switched on by pressing a push-button, is set using the High level (red) potentiometer, (recommended as 80 per cent).

The lighting can also be dimmed to the required level by holding the pushbutton in.

Extended operation is activated by connecting a 10 kΩ resistor to the detector input; see the wiring diagram below.

Note that when power is first switched on, NP-2T DL cannot sense the 10 kΩ resistor at the detector input if the detector senses presence at the same time, which it normally does.

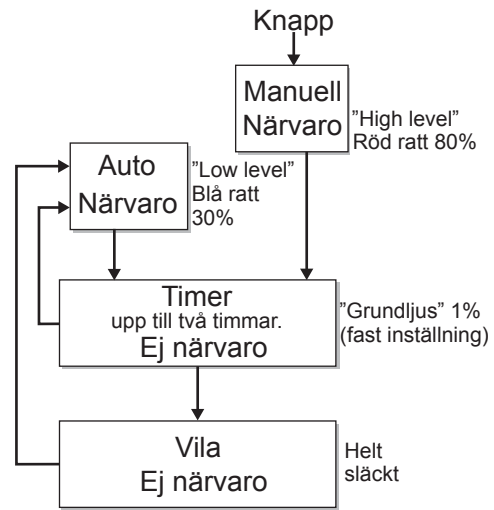

Application examples

One automatic and one manual lighting level (for presence detection or pushbutton operation) e.g. for a gym hall or lunch room.

When the detector detects presence and there is insufficient natural light, the lighting is switched on automatically at the low level, which is recommended as 30 per cent. This lighting level is often adequate for exercising, dancing or during coffee breaks.

The lighting level can be increased, for ball games or lunch, for example, by pressing the pushbutton. This switches the lighting to the higher level, recommended as 80 per cent. The lighting can also be dimmed to the required level by holding the pushbutton in.

When presence is no longer detected the lighting is dimmed to the base level (1 per cent). After 1–2 hours the lighting is switched off completely. This time is set by the Timer potentiometer (yellow). The lighting can also be switched off manually by pressing a pushbutton.

When there is sufficient natural light from the windows the light sensor prevents the lighting from being switched on automatically.

If no light sensor is installed the lighting is always switched on automatically when presence is detected. See the section on Commissioning for information on adjusting the light sensor.

Additional applications where NP-2T DL can be used (1C, 2C, 2D, 2F, 4F, 6A and 6D) can be found in the Energy-saving Detection Technology handbook and at www.extronic.se.

Gymnastiksal eller kafferum med naturligt ljus

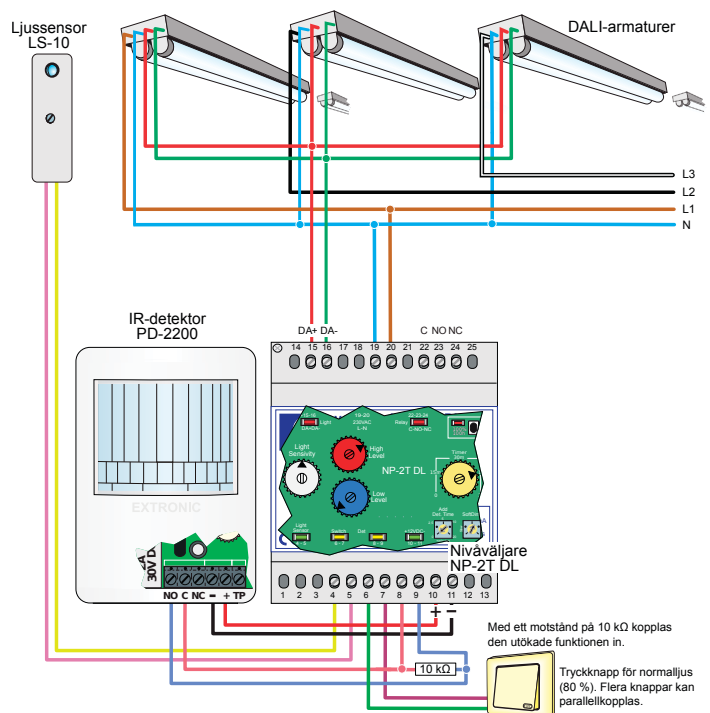
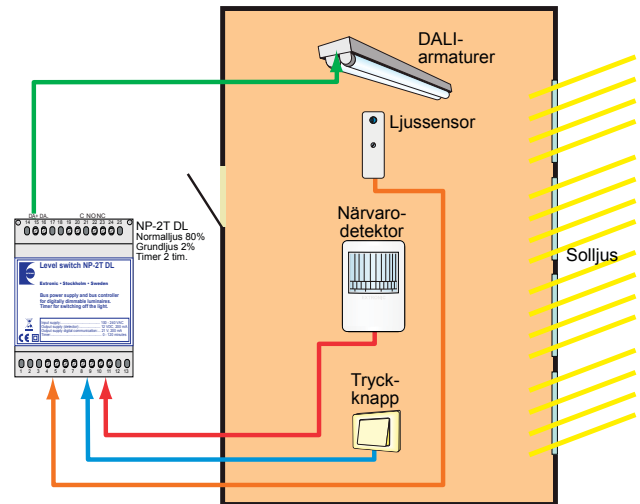

Med ett motstånd på 10 kΩ kopplas den utökade funktionen in.

Tryckknapp för normalljus (80 %). Flera knappar kan parallellkopplas.

Commissioning

Adjusting levels and times

As a standard solution the potentiometers should be adjusted to give the following minimum and maximum levels:

Low level potentiometer – base lighting (Low level, blue) to 1 per cent = lowest possible (fully anticlockwise) or whatever setting the HF ballast permits or gives the desired level of comfort

High level potentiometer – normal lighting (High level, red) to a maximum of 80 per cent. A lux meter can be used to adjust this setting. *To make adjustment of light levels easier the relevant level is switched on for a few seconds every time a level potentiometer is adjusted.*

Timer function (Timer, yellow) controls the switching on and off of lighting (possibly via a contactor). This should be set to 1–2 hours (Base Level). A longer time means that the lighting is switched on fewer times each day.

Longer time = less wear to the cathodes of fluorescent tubes.

Adjust the delay for detector(s) to 1–2 minutes or slightly longer to suit wishes. This time determines how long the lighting remains at the higher level after presence was last detected. This time should therefore be kept as short as possible.

It is very important that the settings for the installation are documented and kept as a record that adjustment has been carried out according to the instructions.

A form for documenting settings can be found in the Energy-saving Detection Technology handbook and at www.extronic.se/dokumentation/manualer.

Add Det. Time potentiometer – detector delay

The detector's additional delay time is set to the required duration, 0–20 minutes.

Light sensor (Light Sensitivity, white potentiometer)

NOTE! The light sensor should be adjusted so that it prevents the lighting from being switched on when there is sufficient natural light.

1. Turn the potentiometer fully anticlockwise to the Min position.
2. Then turn the potentiometer clockwise until the green Start block LED lights up.
3. Now the lighting will not be switched on until the natural light level falls below the level at the time of setting.
4. **NOTE! The lighting will not be prevented from switching on until presence is no longer detected, the lighting has dimmed to the base level and presence is once again detected.**

Dimmer rate (Soft Dim). Should be set so that ramping up takes place at the required rate. The ramp down rate is fixed at around 20 seconds. A good base setting is to adjust the potentiometer to the one o'clock position.

Fluorescent tube burn-in. New fluorescent tubes should be burned in to deliver their rated performance Burn-in entails running the tubes at 100 per cent power for 100 hours.

There is a button on the circuit board that starts the burn-in process for fluorescent tubes:

- A single press turns on the fluorescent tubes at 100% for 100 hours.

- Pressing again interrupts the burn-in process.

During the burn-in process the lighting can be switched on or off and dimmed manually.

Technical specification

Voltage:	230 VAC.
Power supply, DALI bus:	21 V, max. 200 mA.
Power supply, detectors:	12 V, max. 200 mA.
Number of light fittings:	Approx. 100 depending on type.
Relay:	Switching.
Switch-off delay:	0–120 minutes.
Dimensions (W x H x D):	72 x 92 x 76 mm (4 modules).

Optional equipment

PD-2200 presence detector



Order no. 13140, E-no. 13 060 20

PD-2200 is a passive IR detector intended for presence detection. The electronics and software in the microprocessor of the PD-2200 have been specially designed for presence detection. The number 15 standard lens gives a

detection area of 41 m x 41 m.

LS-10 light sensor



Order no. 13100, E-no. 13 060 16

Light sensor for connecting to NP-2T DL, etc. The light sensor monitors the light level in the premises.

AD-500/600 detector



Order no. 13095/13091, E-no. 13 060 10/13 060

12 AD500/600 are acoustic presence detectors for lighting control. These detectors detect presence by listening for sounds in two different frequency ranges and analysing the signals. The lighting is switched on by inaudible low-frequency sound that is generated when a door is opened. The lighting remains on as long as higher frequency sound such as foot-

steps and speech are detected.

AD-300 acoustic auxiliary detector



Order no. 13126, E-no. 13 060 40

AD-300 is an auxiliary acoustic detector intended for use in combination with an IR detector. The purpose of the detector is to switch on lighting when someone enters the premises by detecting the infrasound (low-frequency sound) that is generated

when a door is opened. This improves convenience, by ensuring that lighting is switched on in areas that the IR detector cannot "see", such as concealed doorways.

AD-350 acoustic auxiliary detector



Order no. 13130, E-no. 13 060 41

AD-350 is an auxiliary acoustic detector intended for controlling lighting in combination with an IR detector. It listens solely to a limited frequency range between 3 and 7 kHz and switches on the lighting (or keeps it switched on) when sound is detected in this range, before the IR detector detects presence.

The AD-350 is often used to supplement IR detectors, to ensure that lighting remains on when people are present.