

B.E.G. LUXOMAT® PD4-M-DALI/DSI-C

Installation and Operating Instruction for B.E.G. - Occupancy detector PD4-M-DALI/DSI-C-SM/FC

1. Product information

- Occupancy detector for daylight-dependent lighting control
- Especially for corridors
- DALI / DSI interface for controlling digitally dimmable electronic ballasts as a group
- Switching between DSI and DALI program by remote control or DIP switch
- Extension of the detection area by slave devices is possible
- Other functions adjustable by remote control (optional).
- Manual switching and dimming via pushbutton possible
- Orientation light function

2. Operation

The presence detector controls the light automatically according to people present (movements) and the ambient brightness.

The integrated light sensor constantly measures the ambient light and compares it with the set value brightness on the detector. If the ambient light is sufficient, lighting will not be switched. If the ambient light level is below the set value brightness, a movement activates the lighting in the room.

The detector switches the light off despite of a person being present if there is enough natural light for 5 min or if no movement is detected for one follow-up time.

3. Safety information

- Work on the 110-240 V mains supply may only be carried out by qualified professionals or by instructed persons under the direction and supervision of qualified skilled electrical personnel in accordance with electrotechnical regulations.**
- Disconnect supply before installing!**
- This device is not suitable for disconnection.**
- Mounting the cover ring after introduction of the power cable (FC version)**

4. Mounting

The corridor window in the lense is the essential feature for orientation when mounting the detector (see fig. 1).

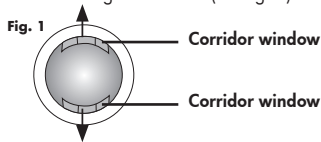

- In master/slave mode, the master device must always be installed at the location with least daylight.
- The light sensor must be positioned facing away from the window.

4a. Mounting SM

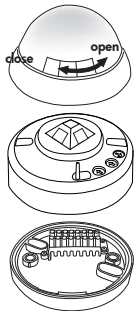

The detector has to be mounted on a plane and solid surface. Before mounting, the lense has to be removed. To do so, twist the lense anticlockwise through approx. 5° and lift off.

Having connected up the cables in accordance with regulations, put on the lense by turning in a clockwise direction (see fig. 2). Apply mains voltage.

Figure 2

4b. Mounting FC

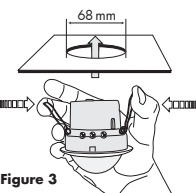

A circular opening of diameter 68 mm must be produced in the ceiling. Having connected up the cables in accordance with regulations, the detector is inserted into the opening and fixed into position with the assistance of the spring clips (see figure 3).

5a. Position DIP switches, LEDs and Potentiometer SM

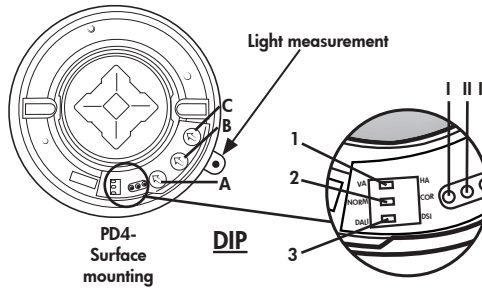

5b. Position DIP switches, LEDs and Potentiometer FC

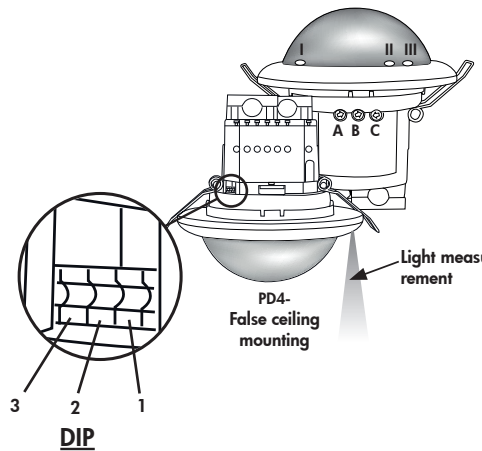

DIP switch functions		
DIP 1	Full automatic mode (VA)	Semi-automatic mode (HA)
DIP 2	Standard mode (NORM)	Corridor mode (COR)
DIP 3	Operation mode DALI	Operation mode DSI

- Potentiometer A** Brightness (constant light control)
- Potentiometer B** Follow-up time light
- Potentiometer C** Follow-up time (orientation light)

- LED I green
- LED II red
- LED III white

Corridor function:

Upon a manual activation of the push button, the detector switches the light off and after 5 s returns to automatic mode.

6. Self test cycle/Startup behavior

The product enters an initial 60-second self-test cycle, when the supply is first connected. During this time the device does not respond to movement and stays on.

7. Putting into operation / Settings

Brightness value for constant light control (Potentiometer A)
The brightness set value can be defined between 10 and 2000 lux. The potentiometer enables a free selection of the brightness value.

Symbol ☾: Night-time operation
Symbol ☀: Daytime operation (Light evaluation inactive)

Follow-up time „Light“ (Potentiometer B)
The follow-up time can be set to 1 to 30 minutes.

Symbol TEST: test mode
Irrespective of the brightness, every movement switches the light on for 1s, then off again for 2s.

Follow-up time orientation light (Potentiometer C)
Manually switching the orientation light on/off.
„ON“ for permanent orientation light
„OFF“ for switching off the orientation light

8. Wiring diagram

Standard mode with Master/Slave

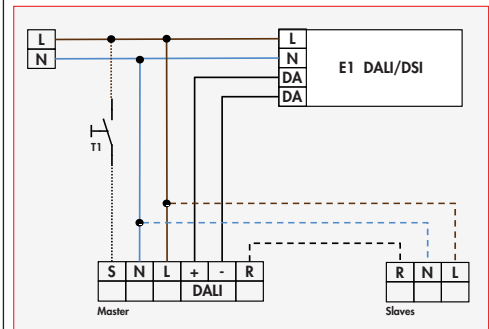

- Connected Slave devices must have the same phase as the Master device.

9. Manual switching and dimming (see section 23)

By pressing the push button, the phase can be given to the S terminal.

To turn on or off the light, press the push button briefly. The light will remain on or off, as long as people are detected plus the follow-up time.

With a long press of the push button the light will be dimmed manually. When releasing the button, the current brightness value is retained.

With renewed long press of the push button, the dimming direction is reversed.

10. Range

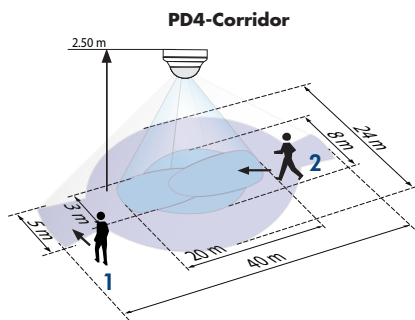

- 1 ■ Walking across
2 ■ Walking towards

11. Exclude sources of interference

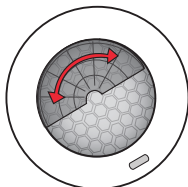

If the detection zone is too large, or areas are covered that should not be monitored, use the blinds to reduce or limit those areas.

12. Technical data

Power supply:	110-240VAC, 50/60 Hz
Power consumption:	ca. 1W
Ambient temperature:	-25°C to +50°C
Degree of protection/class:	IP20 / II
Max. no. of series-connected electronic ballasts:	up to 50 (Broadcast)
Range of coverage Ø	
H 2,5 m / T = 18°C:	tangential 40 m / frontal 10 m
Area of coverage:	circular 360°
Required mounting height:	2.4 m - 2.6 m
Dimensions H x Ø [mm]	SM FC
	63 x 98 103 x 97 mm

CE Declaration of Conformity:

This product respects the directives concerning

1. electromagnetic compatibility (2004/108/EU)
2. low voltage (2006/95/EU)
3. restriction of the use of certain hazardous substances in electrical and electronic equipment (2011/65/EU)

13. Article / Part nr. / Accessory

Type	SM	FC	FM
PD4-Master-DALI/DSI-C	92530	92328	-
PD4-Slave-C	92536	92444	92445

LUXOMAT® Remote control:

IR-PD-DALI-E (incl. wall bracket) - General remote control	92122
IR-PD-DALI (incl. wall bracket)	92094
IR-PD-DALI-Mini	92112
IR-PD-DALI-LD (incl. wall bracket)	92652
IR-RC-Adapter with Smartphone-App	92726

Accessory:

BSK Wire basket	92199
Wall bracket for remote control as replacement	92100
SM-Socket IP54	92161

14. LED function indicators

LED function indicators		
Process	Standard mode	Double-locked
Initialisation time unprogrammed	Red flashes	Green flashes
Initialisation time programmed	Red flashes quickly	Green flashes quickly
Motion detection	Red flashes on each detected movement	Green flashes on each detected movement
Too bright detected	Red flashes 2x per second	Green flashes 2x per second
Too bright / too dark / undefined in opened state	Green flashes very quickly	Green flashes very quickly
Switching DALI/DSI DSI active	Red shines 3 sec.	
Switching DALI/DSI DALL active	Green shines 3 sec.	
Corridor active	White ON 1 sec. and OFF 4 sec.	
Corridor and semi-automatic mode (HA) active	White ON 4 sec. and OFF 1 sec.	
Switching HA/VA Semi-automatic mode (HA) active	White shines permanently	
Switching Preset/User Preset active	Red shines 3 sec.	
Switching Preset/User User active	Green shines 3 sec.	
IR signal valid received	Red and white shine 3 s	
IR signal invalid received	Red shines 0,5 sec.	
100 h function active	Red / Green flash alternately	Red / Green flash alternately
Light measurement in progress	Green flashes 1x in 10 sec.	Green flashes 1x in 10 sec.

15. Settings with remote control (optional) (see also section 24)

Settings with remote control override the potentiometer and DIP settings.

The DIP settings are reactivated by

- setting the potentiometers to „TEST“ and „SUN“ (see section 24), or
- pressing the RESET button on the remote control in open state

Infrared remote control LUXOMAT® IR-PD-DALI-E

• Check Battery:

Open battery compartment by pressing the plastic springs together and removing the battery-holder.

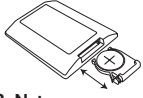

2. Note

Using the remote control, the occupancy detector can only be operated brightness-depending. The setting „SUN“ can only be chosen with potentiometer A.

When using the remote control IR-PD-DALI-E, we recommend to set potentiometer A to „SUN“. Pressing the RESET button on the remote control then resets the detector to brightness-independant mode (SUN).

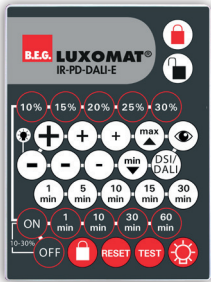

IR-PD-DALI-E

Wall bracket for remote control IR-PD-DALI-E

16. Settings by remote control when open

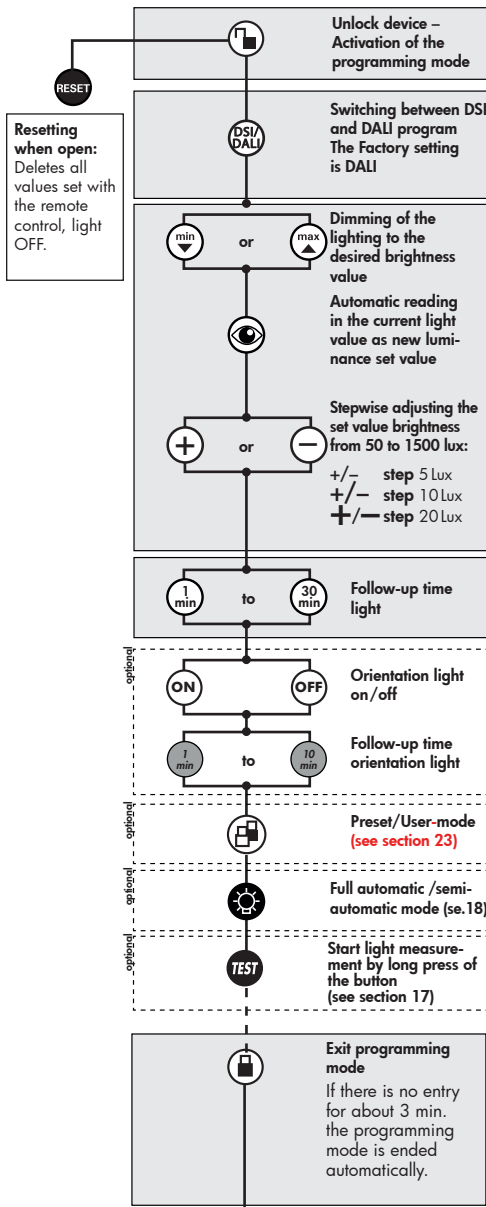

17. Light regulation

The detector has two different integrated light control algorithms. The set value for the first algorithm is adjusted by potentiometer (LUX) on the device. Very small light amounts, which shine directly to the detector, have as result that the set value brightness is exceeded.

The second algorithm has an integrated daylight compensation. Therefore, it is necessary that the detector analyses the switched light quantity. This algorithm can only be used by remote control. The programming of the set value and the measurement of the light quantity is carried out in two steps:

In the open state

- The set value is adjusted without daylight (please darken the room) by using the remote control.
- Measuring the light quantity will be initiated by a long press (> 3 sec) of the test button. The detector turns the light on for 5 min. at 100%. Then the light will turn on and off for a short time and stays on after that. This measuring process is shown by a flashing green LED (10 sec off/ 1 sec on). This measuring process is required for each change of the set value. If the setting "permanet orientation light" is chosen, the function only will be active after the measuring process is done.

If the measuring process is not performed, the detector performs it automatically when the ambient light is less than 50 lux for 1h.

18. Full / Semi-automatic mode

The mode is changed using the button "Light" in the open state. Each time the button is pressed, the current operating mode is indicated by the LEDs:

- Red shines for 3 sec. = Full automatic mode
- Green shines for 3 sec. = Semi-automatic mode

Full automatic operation

In this operating mode, the lighting switches automatically on and off for increased comfort, depending on presence and brightness.

Semi-automatic operation

In this operating mode, the light turns on only after a manual switching, for an increased savings success (see section 22). Switching off is automatically or manually (see section 22). The semi-automatic mode basically behaves like the full automatic mode. The only difference is that the switching on has to be done by hand.

In case motion is detected within the 10s after elapse of the follow-up time, the detector switches the light on again and the follow-up time starts again. If there is no motion detected within the 10s after elapse of the follow-up time, the light has to be turned on manually.

19. Settings during the Self-test cycle

In the first 60 seconds after connecting the AC voltage, the following functions can be set:



INI-OFF/ON mode:

Turn off or turn on the light during the self-test cycle of 60 sec. The last state is active. Factory setting is that the light is on during initialisation.

When INI OFF is chosen, the detector does not switch on the light after voltage supply. Even upon detected movement the light is switched on only after 60 s.



Startup behavior:

The set value can be reached in two ways after switching on. The detector switches the lights on at 10% and then adjusts upwards (min button) or it switches the light on at 100% and regulates down (max button). This is confirmed by a short flashing of the red and white LED as well as the lighting. Factory setting is that the detector switches the light on at 100%.



Reset of electronic ballasts

If required the connected EB can be reset and preset parameter can be deleted. Press the button "Reset" for 3 seconds in initialisation mode.

20. Test mode/Reset



Test mode

Use „Test“ button for activating the test mode and the „Reset“ button to deactivate it.



Reset in closed state

The lighting is switched off, and the follow-up times are reset.



Reset in open state

Pressing the button for >3s deletes all settings (except of INI ON/OFF) and the detector is reset to factory state.

21. 100h function

(long press (> 3 s) when closed)



Before the lamp can be dimmed, the dimming function has to be suppressed for a certain time in order to burn in the lamps.

T5 fluorescent lamps: 80 h

T8 fluorescent lamps: 100 h

For activating the function, press button „Light ON/OFF“ in closed state. During this time, the detector only switches the light ON or OFF. A dimming to the set value does not take place. After having activated the function, the red and green LED flash alternately. By pressing the button „Light ON/OFF“ again, it is possible to deactivate the function before the time has elapsed.

Failure to comply to the burn-in would lead to reducing the life of the lamp. A further disadvantage could be unwanted random variations in light intensity.

22. Manual Switching

(short press when closed)

You can switch the lighting on and off manually by pressing the pushbutton or the remote control button „Light ON/OFF“ for a short time. It will stay on or off as long as people are detected plus the configured follow up time.

23. Manual Dimming - Preset / User

(long press when closed)

You can dim manually by pressing the external push button or the remote control buttons "min/max" – for a long time (> 2sec.). When the button is released, the current dimming value is retained. Upon renewed dimming, the dimming direction is reversed.



Two different operating modes are selected in the opened state.

Changing the mode is done by pressing the "double lock" button. Each time the button is pressed, the current operating mode is indicated:

- Red shines for 3 sec. = Preset
- Green shines for 3 sec. = User

PRESET – the set value brightness is set during start-up operation by the installer and remains unchanged. The set value brightness configured through manual dimming is only applied for the time being.

The constant light regulation is now deactivated! The current set artificial light is retained independent of the ambient/daylight brightness! After switching off and then back on, the original set set value brightness is reset = constant light regulation is activated.

USER can only be activated via the remote control

The set value brightness is changed upon each manual dimming and re-adjusted by the user. The constant light regulation remains activated!

24. Reset the detector

If the double lock is activated, the detector can be opened again as follows:

- Disconnect operating voltage
- Connect operating voltage for 31s to 59s
- Disconnect operating voltage again
- Connect operating voltage again and wait for the self testing
- Open detector

With this procedure, the remote control programmed values are not deleted (before activation of the double lock).

If the setting is not changed by remote control after deactivation of the double lock, the detector changes in the double locked mode again after a period of 30 minutes. This way the detector cannot be unlocked during an accidental power failure.

Alternatively, the detector can be reset in this way:

Set potentiometer A to "Sun" and potentiometer B to "Test". The detector now is in test mode and the potentiometer settings are active. All operating LEDs are flashing for three seconds.

Except of the INI ON/OFF setting, the detector is reset to factory setting or the setting of the potentiometer.

Pushing the „RESET“ button on the remote control, in opened mode, will delete all of the values which were set by the remote control (beside of INI ON/OFF) and set the detector back to its factory settings.

Factory settings

The detector is delivered with the following factory settings: lux value: 500 Lux, follow-up time: 10 minutes. Starting the detector in the factory program the initialisation mode starts with a constant flashing of the three operating LEDs.