

Installation and Operating Instruction for B.E.G. - Occupancy detector PD4-M-DALI/DSI-SM/FC

1. Product information

- Occupancy sensor for daylight-dependent lighting control
- DALI / DSI interface for controlling digitally dimmable electronic ballasts as a group
- Switching between DSI and DALI program by remote control or DIP switches
- Version as Master
- Extension of the coverage area by slave devices are possible
- Other functions can be adjustable by remote control.
- Manual switching and dimming via pushbutton possible
- Orientation light function

2. Operation

The presence detector controls the light automatically according to people present (movements) and the ambient brightness.

The integrated light sensor constantly measures the ambient light and compares it with the brightness level on the detector. If the ambient light is sufficient, lighting will not be switched. If the ambient light level is below the brightness level, a movement activated the lighting in the room.

The detector switch the light off instead of a person, if there is enough natural light for 5 min. or until the follow-up time do not recognized any movement in the room.

3. Safety information

Work on the 230V mains supply may only be carried out by qualified professionals or by instructed persons under the direction and supervision of qualified skilled electrical personnel in accordance with electrotechnical regulations.

Disconnect supply before installing!

This device is not suitable for disconnection.

Mounting the cover ring, after introduction of the power cable (FC version)

4a. Mounting SM

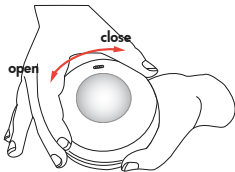

The detector must be mounted on a flat solid ground. Before mounting the detector, the lens must be removed. The circular cover ring must be removed prior to assembly. To do this, twist the circular cover ring of the PD2 anticlockwise through approximately 5° and lift off.

Having connected up the wires in accordance with regulations, put on the cover ring by turning in a clockwise direction. Apply mains voltage.

4b. Mounting FC

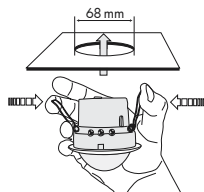

A circular opening of diameter 68 mm must be produced in the ceiling. Having connected up the cables in accordance with regulations, the detector is inserted into the opening as shown in the drawing opposite and fixed into position with the assistance of the spring clips.

In Master/Slave-operation the master device must always be installed at the site with less daylight.

The light sensor should be mounted on the opposite side of the window.

5a. Position DIP-Switches, LEDs and Potentiometer SM

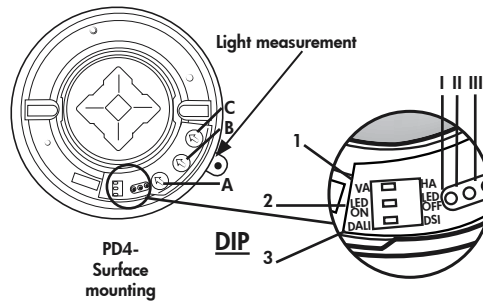

5b. Position DIP-Switches, LEDs and Potentiometer FC

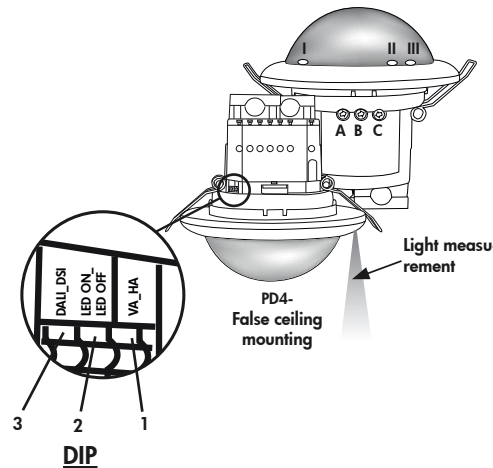

| DIP-switch function | | |
|---------------------|---------------------------|--------------------------|
| DIP 1 | Fully automatic mode (VA) | Semi automatic mode (HA) |
| DIP 2 | LED ON | LED OFF |
| DIP 3 | operation mode DALI | operation mode DSI |

Potentiometer A Brightness constant light control

Potentiometer B Off delay for light

Potentiometer C Orientation lighting

LED I green

LED II red

LED III white

6. Self test cycle/Startup behavior

The product enters an initial 60-second self-test cycle, when the supply is first connected. During this time the device does not respond to movement and stays on. (INI-ON or INI-OFF)

The initialization mode can be changed by using the remote control

7. Putting into operation / Settings

TIME
Follow-up time for light control
The time can be set infinitely variably between 1 and 30 minutes.

Symbol TEST: Test mode
Every movement switches on the light for a period of 1 second, switching it off for a period of 2 seconds.

Twilight-switch for light control (relay 1)
The switch-on value for the light can be set at between 10 and 2000 lux. Using the rotary control, the luminance set points can be set as desired.

Symbol Night-time operation
Symbol Daytime operation

Orientation lighting
The orientation lighting can be set infinitely variably at between 5 and 60 minutes resp. "ON" for permanent orientation lighting or "OFF" for no orientation lighting. "ON" for permanent orientation lighting "OFF" deactivation of orientation lighting.

Pulse spacing PD-Slave
2 or 9 seconds can be set for the pause between 2 pulses sent to the master. The setting can be made with activated (●) or deactivated (○) LED indicator.
For devices with a separate Slave input, 2 sec. can be set.

8. Wiring diagram

Standard mode with Master/Slave

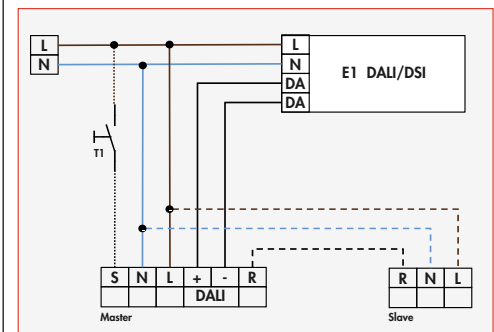

Connected Slaves must have the same phase as the Master.

9. Manual switching and dimming

By pressing the push button, the phase can be given to the S terminal.

To turn on or off, press the push button briefly. The light will remain on or off, as people are detected plus the follow-up time.

With a long key press the light will dimmed manually. When you release the button, the current brightness value is retained. With renewed dimming, the dimming direction is reversed.

10. Range

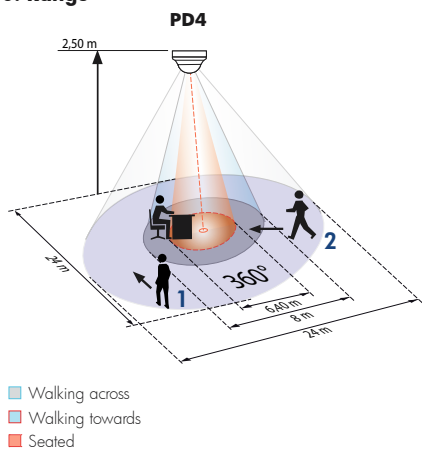

11. Exclude sources of interference

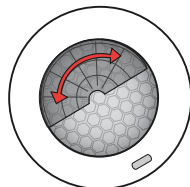

If the detection zone is too large, or areas covered that should not be monitored, use the blinds to reduced or limited those areas.

12. Technical data

| | |
|--|---|
| Power supply: | 110-240 V~, 50/60 Hz |
| Power consumption: | < 1 W |
| Ambient temperature: | -25°C to +50°C |
| Degree of protection/class: | IP20 / II |
| Max. no. of series-connected electronic ballasts: | up to 50 (Broadcast) |
| Recommended height for mounting: | 2 - 3 m |
| Range of coverage Ø | |
| H 2,5 m / T = 18°C: | seated 4 m / tangential 10 m / radial 6 m |
| Area of coverage: | circular 360° |
| Dimensions H x Ø [mm] | SM 50 x 97 FC 84,5 x 74 mm |

Technical data PD4 Slave

| | |
|--------------------------|----------------------|
| Power supply: | 110-240 V~, 50-60 Hz |
| Impulse output: | Optocoupler max. 2 W |
| Impulse duration: | 2 sec. or 9 sec. |
| Dimensions: | see above |

CE Declaration of Conformity: The product complies with the low voltage recommendation 2006/95/EC and the EMV recommendation 2004/108/EC.

WE RECOMMEND THAT BEFORE DIMMING OF THE CONNECTED LIGHTS A 100h BURN IN (T5 TUBES OR 80 HOURS FOR T8 TUBES) FUNCTION TAKES PLACE.

THE LIFESPAN OF THE LAMPS CAN BE REDUCED IF THE BURN IN DOES NOT TAKE PLACE.

13. Article / Part nr. / Accessory

| Typ | SM | FC | FM |
|---------------------|-------|-------|-------|
| PD4-Master-DALI/DSI | 92279 | 92275 | - |
| PD4-Slave | 92142 | 92254 | 92163 |

LUXOMAT® Remote control:
IR-PD-DALI (incl. wall bracket) 92094

Accessory:
BSK Ball basket guard 92199
SM-Socket IP54 92161

14. LED-functional indicators

| LED-functional indicators | | |
|---|---------------------------------------|---|
| Process | Standard mode | Double-locked |
| Initialisation time unprogrammed | Red flashes | Green flashes |
| Initialisation time programmed | Red flashes quickly | Green flashes quickly |
| Motion detection | Red flashes on each detected movement | Green flashes on each detected movement |
| Too bright detected | Red flashes 2x each second | Green flashes 2x each second |
| Too bright / too dark / undefined in opened state | Red flashes very quickly | Green flashes very quickly |
| Switching DALI/DSI DSI active | Red shines 3 sec. | |
| Switching DALI/DSI DALI active | Green shines 3 sec. | |
| Switching HA/VA VA active | Red shines 3 sec. | |
| Switching HA/VA VA active | Green shines 3 sec. | |
| Switching Preset/User Preset active | Red shines 3 sec. | |
| Switching Preset/User User active | Green shines 3 sec. | |
| IR signal valid received | Red and white shines 3 s | |
| IR signal invalid received | Red shines 0,5 sec. | |
| 100h Function active | Red / Green flashes variable | Red / Green flashes variable |
| Light measurement in progress | Green shines 1x in 10 sec. | Green shines 1x in 10 sec. |

13. Settings by remote control when open

Settings with remote control override the potentiometer and DIP settings.

The DIP settings are reactivated by

- Reset with Test-Sun setting at the potentiometers
- „RESET” in the opened state

Remote control LUXOMAT® IR-PD-DALI

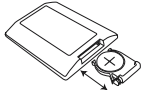

1. Check Battery:

Open battery compartment by pressing the plastic springs together and removing the battery-holder.

2. Note:

The operable distance of the remote control depends on the brightness. The brighter the less distance the remote could reach the occupancy detector. The setting for "SUN" could only be set with the potentiometer.

By using the remote control IR-PD-DALI, we recommend to set potentiometer 2 on "SUN". Pushing the RESET button (remote control) would reset the brightness independence of the occupancy detector (SUN).



IR-PD-DALI

Wall bracket for remote control IR-PD-DALI

14. Settings by remote control when open

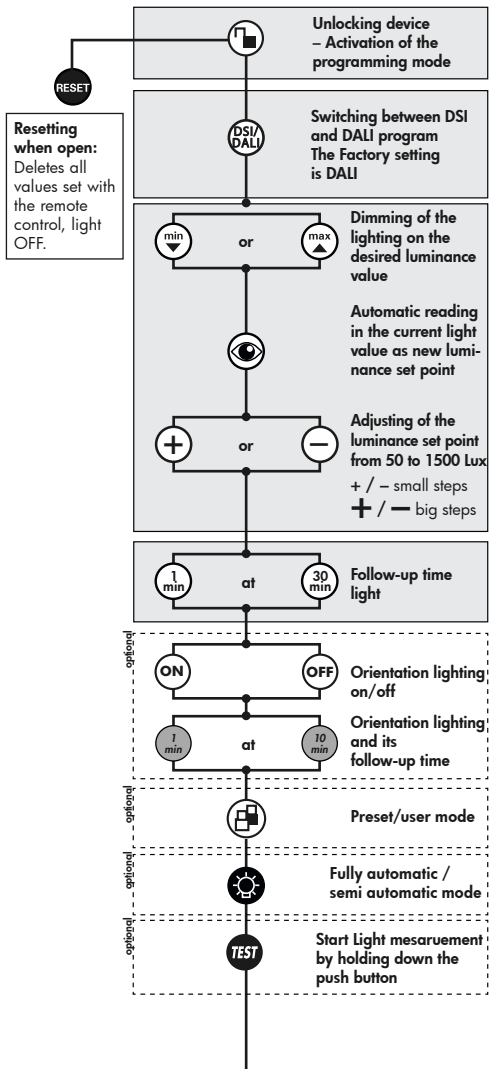

18. Light regulation

The detector has two integrated light control algorithms. The set value for the first algorithm is adjusted by potentiometer (LUX) on the device. Very small light amounts, which shine directly to the detector, have the result of a trigger under control of the set value.

The second algorithm has an integrated daylight compensation. Therefore it is necessary, that the detector analyzes the switched light quantity. This algorithm can only be used by remote control. The programming of the setpoint value and the measurement of the light quantity in two steps:

In the open state

- The set value will be without daylight (no light in room) adjusted by using the remote control.
- Measuring the light quantity, will be initiated by a long press (> 3 sec) at the test button. The detector turns the light on for 5 min. up to 100%. Then the light will be on and off for a short time and stays on after that. This measuring process is shown by a flashing green LED (10 sec on / 1 sec on). This measuring process is required for each change of the set value.

If the measuring process is not performed, the detector performs this automatically, when the ambient light is for 1 h less than 50 LUX.

19. Fully / Semi automatic mode

The system switches over when the "Light" push-button is open. Each time a push button is pressed, the current operating mode is indicated by the red LED:
Red lights for 3 sec. = Fully automatic mode
Green lights for 3 sec. = Semiautomatic mode

Fully automatic operation

In this operating mode, the lighting switches automatically on and off for increased comfort, depending on presence and brightness.

Semi automatic operation

In this operating mode the light turns on only after a manual switching, for a increased savings success. Switching off is automatically or manually.

19. Settings during the Self-test cycle

In the first 60 seconds after connecting the AC voltage, the following functions can be set:



INI-OFF/ON-Mode:

Turn off or turn on the detector during the self-test cycle of 60 sec. The final state is active. Factory settings of the light is on during initialization.



Initialization mode INI-OFF the detector does not turn on after the power supply voltage. A movement switch on the detector after 60 seconds.



Startup behavior:

The setpoint value can be started after switching on in two ways. The detector switches the lights on to 10% and then adjusts upward (min button) or it switches the light on 100% and regulates down (max button). This is confirmed by a short flashing of red and white LED lighting. By factory default setting, detector switches the light to 100% and regulates toward the set point.

20. Self-test cycle/Reset



Testmode
Disable the test mode



Resetting when closed
The lighting relay is switched off, i.e. opened and the follow-up times reset.

21. 100h Function

(long press when closed)

T5 and T8 are recommended to burn-in for 100h at maximum brightness before dimming. This would prolong the life of the lamp.

At the 100h-Function the detector only switch on and off. A regulation to a set value will be suppressed. The light has to be on for 100h, until the set value get regulated.

The 100h will be activated by pressing a long button press (>3 sec.). An activated time can be stopped by pressing a long button press again. The red/green LED shows if the function gets activated.



Before you can dimmed analog or digital, is a suppression of the dimming function for 100h at T5-or 80h at T8 fluorescent lamps and 100% of nominal light necessary.

Failure to comply to the 100h burn-in would lead to the shorten of the life of the lamp. Conditional random variations in light intensity can be the result.

22. Manual Switching

(short press when closed)

You can switch the lighting on and off manually by pressing the pushbutton for a short time. It will stay on or off as long as people are detected plus the configured follow up time.

23. Manual Dimming - Preset/User

You can dim manually by pressing the push button for a long time (> 2sec.). When the button is released, the current dimming value is retained. Upon renewed dimming, the dimming direction is reversed.



Two different operating modes are selected in the opened state.

The system switches over when the "Doublelock" push-button is open (see remote control functions, page 1). Each time a push-button is pressed, the current operating mode is indicated:

Red lights for 3sec. = Preset
Green lights for 3sec. = User

PRESET – the luminance set point is set during start-up operation by the installer and remains unchanged. The luminance set-point configured through manual dimming is only applied for the time being.

The constant light regulation is now deactivated! The current set artificial light is retained independent of the ambient/daylight brightness! After switching off and then back on, the original set luminance set-point is reset = constant light regulation is activated.

USER – can only be activated via the remote control!

The luminance set-point is changed upon each manual dimming and re-adjusted by the user. The constant light regulation remains activated!

24. Reset the detector

If the permanent sabotage protection is activated, the detector can be released again as follows:

- Switch off the power supply and switch it back on
- Let the sensor to initialize for 31 to 59 secs.
- Switch off the power supply again
- Apply power again and wait for the self testing
- Press the unlock

With this procedure, the remote control programmed values are not deleted (before activation of the sabotage protection).

Alternatively, the detector can be reset in this way:

- Switch off the power supply
- Set potentiometer 1 to "test" and potentiometer 2 to "SUN"
- Apply operating voltage

Except of the INI ON/OFF setting, the detector will be reset to factory setting or the setting of the potentiometer.

Pushing the "RESET" button on the remote control, in opened mode, will delete all of the values which was set by the remote control (beside of INI ON/OFF) and set the detector back to it's factory reset.

