

B.E.G. LUXOMAT® net PD2-M-DALI/DSI-HVAC

Installation and Operating Instruction for B.E.G. - Occupancy detector PD2-M-DALI/DSI-HVAC-FC

1. Product information

- Occupancy detector for daylight-dependent lighting control
- DALI/DSI interface for controlling digitally dimmable electronic ballasts as a group
- One additional potential-free switching channel having innovative functions: totally switching off electronic ballasts when used for control of lighting or delay of the HVAC function when used for control of HVAC devices becomes possible
- Alarm pulse: the detector triggers only when three movements are detected within 9 seconds
- Switching between DALI and DSI programming possible with DIP switch and remote control
- Orientation light function
- Version as Master device
- Detection area can be extended with Slave devices
- Manual switching and dimming via push button possible
- Additional functions can be set up using the optional remote control.
- Factory settings 10 min and 500 lux

2. Operation

The presence detector controls the light automatically according to people present (movements) and the ambient brightness.

The integrated light sensor constantly measures the ambient light and compares it with the set value brightness on the detector. If the ambient light is sufficient, lighting will not be switched.

If the ambient light level is below the set value brightness, a movement activates the lighting in the room.

The detector switches the light off despite of a person being present if there is enough natural light for 5 min or if no movement is detected for one follow-up time.

3. Safety information

Work on the 110-240V mains supply may only be carried out by qualified professionals or by instructed persons under the direction and supervision of qualified skilled electrical personnel in accordance with electrotechnical regulations.



Disconnect supply before installing!

This device is not suitable for disconnection.

Mounting the cover ring, after introduction of the power cable (FC version).

4. Mounting

In Master/Slave operation the Master device must always be installed at the site with less daylight.

The light sensor should be mounted on the opposite side of the window.

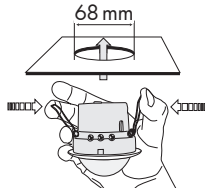

A circular opening of diameter 68 mm must be produced in the ceiling. Having connected up the cables in accordance with regulations, the detector is inserted into the opening as shown in the drawing and fixed into position with the assistance of the spring clips.

5. Position DIP switches, LEDs and Potentiometers

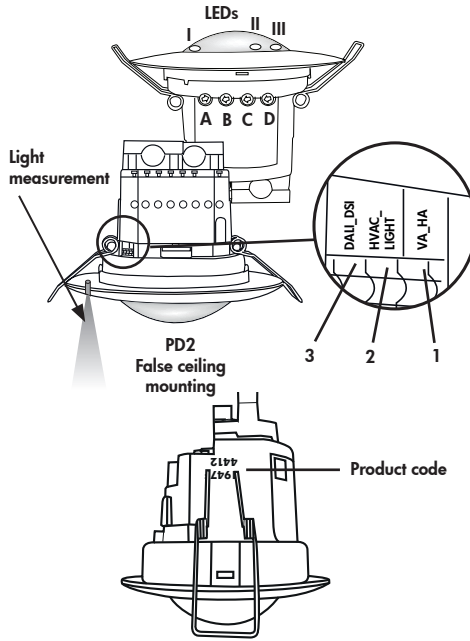

6. Self test cycle/Startup behavior

The product enters an initial 60-second self-test cycle, when the supply is first connected. During this time the device does not respond to movement and stays on.

7. Putting into operation / Settings

Brightness value for constant light control (Potentiometer A)

The brightness set value can be defined between 10 and 2000 lux. The potentiometer enables a free selection of the brightness value.

Symbol Night-time operation

Symbol Day-time operation (Light evaluation inactive)

Follow-up time for light control (Potentiometer B)

The follow-up time can be set to 1 to 30 minutes.

Symbol **TEST**: test mode
Irrespective of the brightness, every movement switches the light on for 1s, then off again for 2s.

Follow-up time for orientation light (Potentiometer C)

The follow-up time can be set infinitely variably at between 5 and 60 minutes. Manually switching ON/OFF the orientation light.

“ON” for permanent orientation light
“OFF” for deactivation of orientation light

Follow-up time for device control (Potentiometer D)

The follow-up time can be adjusted between 5 min. and 120 min. The delay is active from a set time of >15 minutes. This delay is about 5 min. If no other movements are detected during this time, the delay starts again.

Impulse function

The impulse function can be used to control external HVAC systems. All 9 sec. will be set an impulse of 2.5 sec.

Alarm impulse

In order to initiate an alarm impulse, there have to be three detected movements within a period of 9 sec. This function can be used to display a presence in the room on external visualizations. All 9 sec. will be set an impulse of 2.5 sec.

The device does not fulfil the requirements of DIN EN50131-2:2 and therefore cannot be used in professional intrusion detection systems.

| DIP switch functions | | |
|----------------------|---------------------|---------------------|
| DIP 1 | Full automatic mode | Semi-automatic mode |
| DIP 2 | HVAC function | Light control* |
| DIP 3 | Operation mode DALI | Operation mode DSI |

*If you select “LIGHT”, the switching relay R2 operates synchronously to the DALI light channel. The potentiometer R2 has no function in this setting.

Potentiometer A Brightness (constant light control) channel 1

Potentiometer B Follow-up time (light) channel 1

Potentiometer C Follow-up time (orientation light)

Potentiometer D Follow-up time (device control) channel 2

LED I green

LED II red

LED III white

8. Wiring diagram

Standard mode with Master/Slave

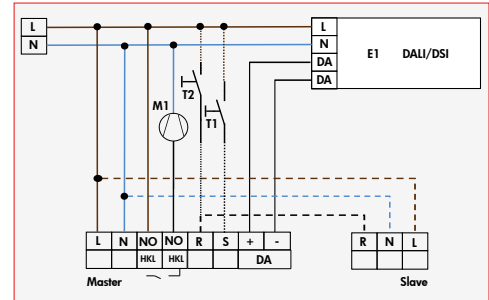

9. Manual switching and dimming

By pressing the push button, the phase can be given to the S terminal.

To turn on or off the light, press the push button briefly. The light will remain on or off, as long as people are detected plus the follow-up time.

With a long press of the push button the light will be dimmed manually. When releasing the button, the current brightness value is retained.

With renewed long press of the push button, the dimming direction is reversed.

Taking the phase to the R terminal by using a button, the HVAC channel can be switched with a short key press.

10. Range

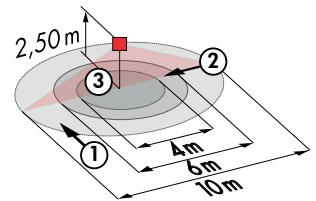

| Height | ① | ② | ③ |
|--------|-----------|-----------|----------|
| 2.50 m | ∅ 10.00 m | ∅ 6.00 m | ∅ 4.00 m |
| 5.00 m | ∅ 20.00 m | ∅ 12.00 m | - |

Connected Slave devices must have the same phase as the Master device.

11. Exclude sources of interference

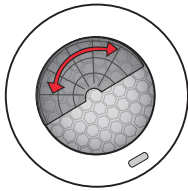

If the detection zone is too large, or areas are covered that should not be monitored, use the blinds to reduce or limit those areas.

12. Technical data

Voltage: 110-240 VAC, 50/60 Hz
Power consumption: approx. 1W
Detection area: 360°
Ambient temperature: -25°C to +50°C
Degree / class of protection: IP20 / II
Recommended mounting height: 2.5 m
Range Ø
H 2.5 m / T = 18°C: smaller movements 4 m / across 10 m / towards 6 m

Dimensions H x Ø [mm]

FC
 84.5 x 80 mm
 15 x 80 mm
Brightness set value: 10 - 2000 Lux

• Channel 1 (lighting control)

DALI output: up to 50 DALI / DSI EB
Follow-up time: 1 min - 30 min
Orientation light: 10 % - 30 % / OFF / 5 min - 60 min / ∞
Brightness set value: 10 - 2000 Lux

• Channel 2 (lighting control or HVAC control, potential-free (dry))

Type of contact: µ-contact, dry NO contact with tungsten pre-make contact
Switching power: 2300 W, cosφ = 1; 1150 VA, cosφ = 0.5

max. inrush current I_p (20ms): 165 A
Follow-up time: 5 min-120 min, Alarm pulse, Pulse

EU Declaration of conformity:

This product respects the directives concerning

1. electromagnetic compatibility (2014/30/EU)
2. low voltage ((2014/35/EU)
3. restriction of the use of certain hazardous substances in electrical and electronic equipment (2011/65/EU)



13. Article / Part nr. / Accessory

| Typ | FC |
|------------------------------|-------|
| PD2-M-DALI/DSI-HVAC (Master) | 92698 |
| PD2-S (Slave) | 92166 |

LUXOMAT® Remote control:

IR-PD-DALI-1C (incl. wall bracket) 92116
 IR-PD-DALI-Mini 92112
 IR-Adapter with smartphone app 92726

Accessories:

BSK Wire basket 92199

14. LED function indicators

| LED function indicators | | |
|---|---------------------------------------|---|
| Process | Standard mode | Double-locked |
| Initialisation time unprogrammed | Red flashes | Green flashes |
| Initialisation time programmed | Red flashes quickly | Green flashes quickly |
| Motion detection | Red flashes on each detected movement | Green flashes on each detected movement |
| Too bright detected | Red flashes 2x per second | Green flashes 2x per second |
| Too bright / too dark / undefined in opened state | Red flashes very quickly | Green flashes very quickly |
| Toggle DALI/DSI DSI active | Red shines 3 sec. | |
| Toggle DALI/DSI DALI active | Green shines 3 sec. | |
| Toggle HA/VA HA active | White shines permanently | |
| Toggle Preset/User Preset active | Red shines 3 sec. | |
| Toggle Preset/User User active | Green shines 3 sec. | |
| IR signal valid received | Red and white shine 3 sec. | |
| IR signal invalid received | Red shines 0.5 sec. | |
| 100 h function active | Red / Green flash alternately | Red / Green flash alternately |
| Light measurement in progress | Green flashes 1x in 10 sec. | Green flashes 1x in 10 sec. |

15. Putting into operation of the remote control (optional)

Settings with remote control override the potentiometer and DIP settings.

The DIP settings are reactivated by

- setting the potentiometers to "TEST" and "SUN" (see section 24), or
- pressing the "Reset" button on the remote control in open state

LUXOMAT® IR-PD-DALI-1C



1. Check Battery:

Open battery compartment by pressing the plastic springs together and removing the battery-holder.

2. Note:

Using the remote control, the occupancy detector can only be operated brightness-depending. The setting „SUN“ can only be chosen with potentiometer A.

When using the remote control IR-PD-DALI-1C, we recommend to set potentiometer A to „SUN“. Pressing the RESET button on the remote control then resets the detector to brightness-independant mode (SUN).



IR-PD-DALI-1C

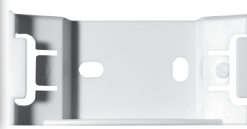

Wall bracket for remote control IR-PD-DALI-1C

16. Settings by remote control in open state

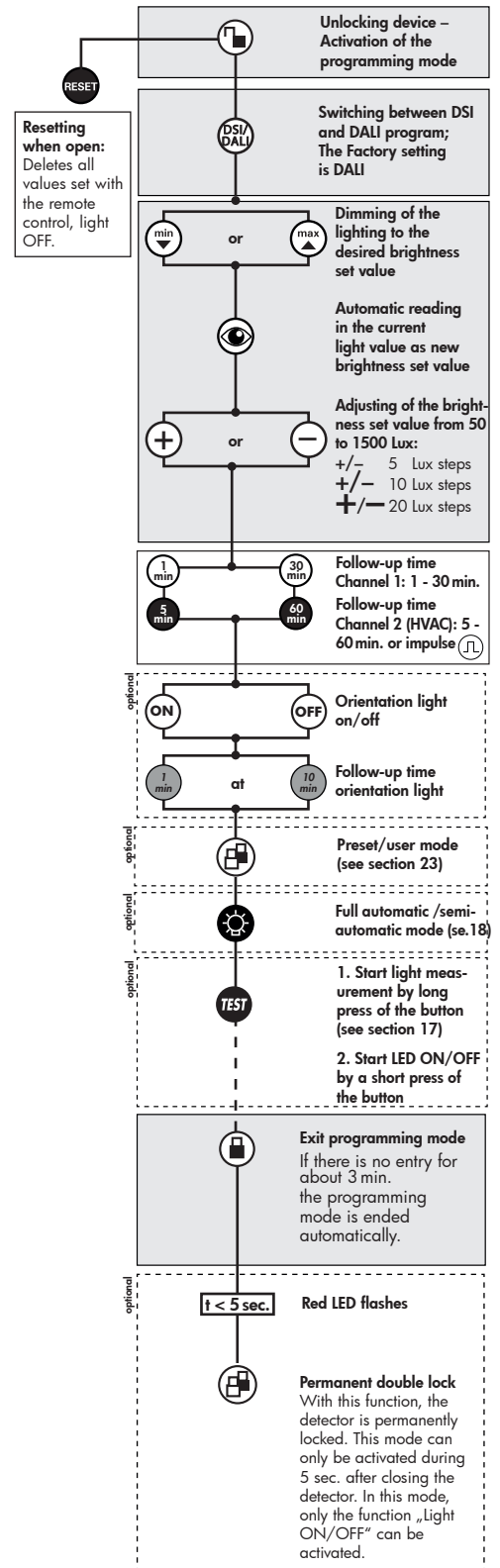

17. Light regulation

The detector has two different integrated light control algorithms. The set value for the first algorithm is adjusted by potentiometer (LUX) on the device. Very small light amounts, which shine directly to the detector, have as result that the set value brightness is exceeded.

The second algorithm has an integrated daylight compensation. Therefore, it is necessary that the detector analyses the switched light quantity. This algorithm can only be used by remote control. The programming of the set value and the measurement of the light quantity is carried out in two steps:

In the open state

- The set value is adjusted without daylight (please darken the room) by using the remote control.
- Measuring the light quantity will be initiated by a long press (> 3 sec.) of the test button. The detector turns the light on for 5 min. at 100%. Then the light will turn on and off for a short time and stays on after that. This measuring process is shown by a flashing green LED (10 sec. off/ 1 sec. on). This measuring process is required for each change of the set value.

 If the setting "perman orientation light" is chosen, the function only will be active after the measuring process is done.

If the measuring process is not performed, the detector performs it automatically when the ambient light is less than 50 lux for 1 h.

18. Full / Semi-automatic mode

The mode is changed using the button "Light" in the open state. Each time the button is pressed, the current operating mode is indicated by the LEDs:

Red shines for 3 sec. = Full automatic mode

Green shines for 3 sec. = Semi-automatic mode

Full automatic operation

In this operating mode, the lighting switches automatically on and off for increased comfort, depending on presence and brightness.

Semi-automatic operation

In this operating mode, the light turns on only after a manual switching, for an increased savings success (see section 22). Switching off is automatically or manually (see section 22). The semi-automatic mode basically behaves like the full automatic mode. The only difference is that the switching on has to be done by hand.

In case motion is detected within the 10 sec. after elapse of the follow-up time, the detector switches the light on again and the follow-up time starts again. If there is no motion detected within the 10s after elapse of the follow-up time, the light has to be turned on manually.

19. Settings during the Self-test cycle

In the first 60 seconds after connecting the AC voltage, the following functions can be set:



INI-OFF/ON mode:

Turn off or turn on the light during the self-test cycle of 60sec. The last state is active. Factory setting is that the light is on during initialisation.

 When INI OFF is chosen, the detector does not switch on the light after voltage supply. Even upon detected movement the light is switched on only after 60 sec.



Startup behavior:

The set value can be reached in two ways after switching on. The detector switches the lights on at 10% and then adjusts upwards (min button) or it switches the light on at 100% and regulates down (max button). This is confirmed by a short flashing of the red and white LED as well as the lighting. Factory setting is that the detector switches the light on at 100%.



Reset of electronic ballasts

If required the connected EB can be reset and preset parameter can be deleted. Press the button "Reset" for 3 seconds in initialisation mode.

20. Test mode/Reset



Test mode

Use "Test" button for activating the test mode.



Use the "Reset" button to deactivate it.

Reset in closed state

The lighting is switched off, and the follow-up times are reset.

Reset in open state

Pressing the button for >3 sec. deletes all settings (except of INI ON/OFF) and the detector is reset to factory state.

21. 100 h function

(long press (> 3 sec.) when closed)



Before the lamp can be dimmed, the dimming function has to be suppressed for a certain time in order to burn in the lamps.

T5 fluorescent lamps: 80 h

T8 fluorescent lamps: 100 h

For activating the function, press button "Light ON/OFF" in closed state. During this time, the detector only switches the light ON or OFF. A dimming to the set value does not take place. After having activated the function, the red and green LED flash alternately.

By pressing the button "Light ON/OFF" again, it is possible to deactivate the function before the time has elapsed.

Failure to comply to the burn-in would lead to reducing the life of the lamp. A further disadvantage could be unwanted random variations in light intensity.

22. Manual Switching

(short press when closed)

You can switch the lighting on and off manually by pressing the pushbutton or the remote control button "Light ON/OFF" for a short time. It will stay on or off as long as people are detected plus the configured follow up time.

23. Manual Dimming - Preset / User

(long press when closed)

You can dim manually by pressing the external push button or the remote control buttons "min/max" – for a long time (> 2 sec.). When the button is released, the current dimming value is retained. Upon renewed dimming, the dimming direction is reversed.



Two different operating modes are selected in the opened state.

Changing the mode is done by pressing the "double lock" button. Each time the button is pressed, the current operating mode is indicated:

Red shines for 3 sec. = Preset

Green shines for 3 sec. = User

PRESET – the set value brightness is set during start-up operation by the installer and remains unchanged. The set value brightness configured through manual dimming is only applied for the time being.

The constant light regulation is now deactivated! The current set artificial light is retained independent of the ambient/daylight brightness! After switching off and then back on, the original set set value brightness is reset = constant light regulation is activated.

USER can only be activated via the remote control

The set value brightness is changed upon each manual dimming and re-adjusted by the user. The constant light regulation remains activated!

24. Reset the detector

If the double lock is activated, the detector can be opened again as follows:

- Disconnect operating voltage
- Connect operating voltage for 31 sec. to 59 sec.
- Disconnect operating voltage again
- Connect operating voltage again and wait for the self testing
- Open detector

With this procedure, the remote control programmed values are not deleted (before activation of the double lock).

If the setting is not changed by remote control after deactivation of the double lock, the detector changes in the double locked mode again after a period of 30 minutes. This way the detector cannot be unlocked during an accidental power failure.

Alternatively, the detector can be reset in this way:

Set potentiometer A to "Sun" and potentiometer B to "Test". The detector now is in test mode and the potentiometer settings are active. All operating LEDs are flashing for three seconds.

Except of the INI ON/OFF setting, the detector is reset to factory setting or the setting of the potentiometer.

Pushing the "RESET" button on the remote control, in opened mode, will delete all of the values which were set by the remote control (beside of INI ON/OFF) and set the detector back to its factory settings.

Factory settings

The detector is delivered with the following factory settings: lux value: 500 Lux, follow-up time: 10 minutes.

Starting the detector in the factory program the initialisation mode starts with a constant flashing of the three operating LEDs.