

PPAD-C-HB-DALI-ADDR

High sensitivity PIR DALI Network

Overview



The PPAD-C-HB-DALI-ADDR is a combined passive infrared (PIR) motion sensor and photocell designed to be part of a DALI network. The PPAD-C-HB-DALI-ADDR is a high sensitivity PIR detector suitable for high bay applications, such as warehouses and factories, and where high detection sensitivity is needed

Functioning as a presence detector, the unit returns occupancy data to the DALI network.

The photocell provides a lux level measurement value to the DALI network.

Features & wiring

Front features

Mounting Bezel

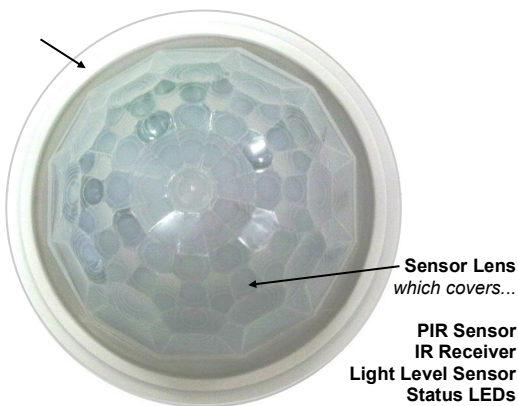

Back features

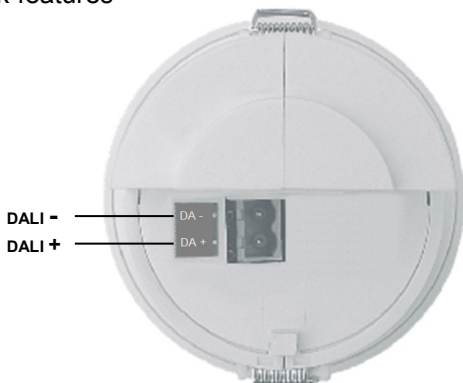

Dimensions

PPAD-C-HB-DALI-ADDR

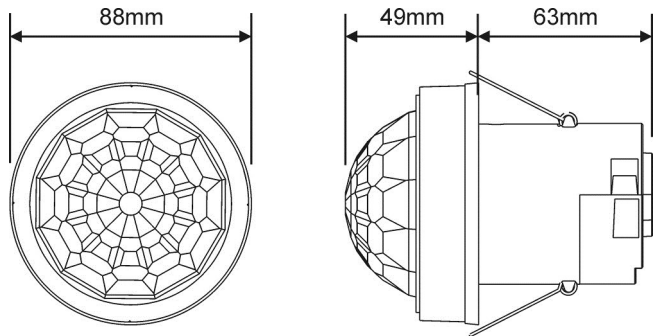

MPAD-C-SURFACE BOX

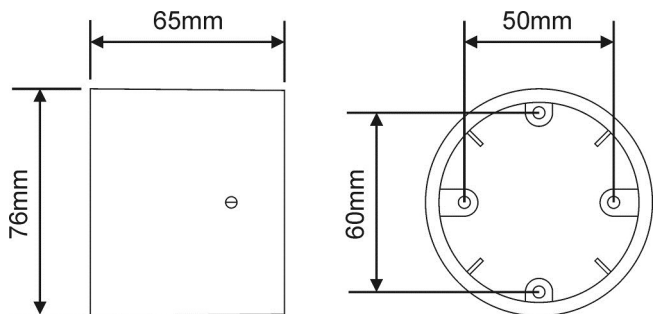

Note: always check the number of DALI addressable devices on any DALI loop as well as the DALI power supply loading to ensure limits are not exceeded. Do not exceed 8 DALI sensors per DALI loop.

Detection diagrams

Range

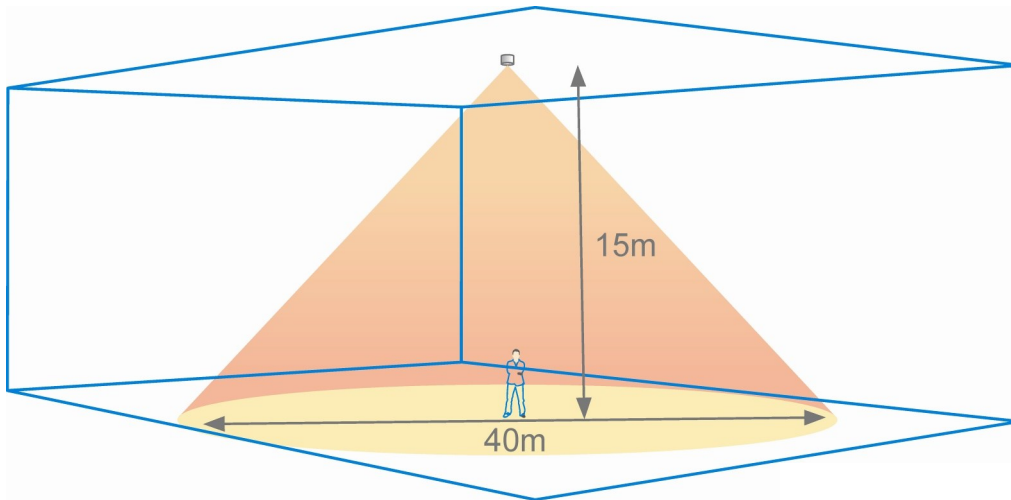

Maximum mounting height 20m

Detection pattern

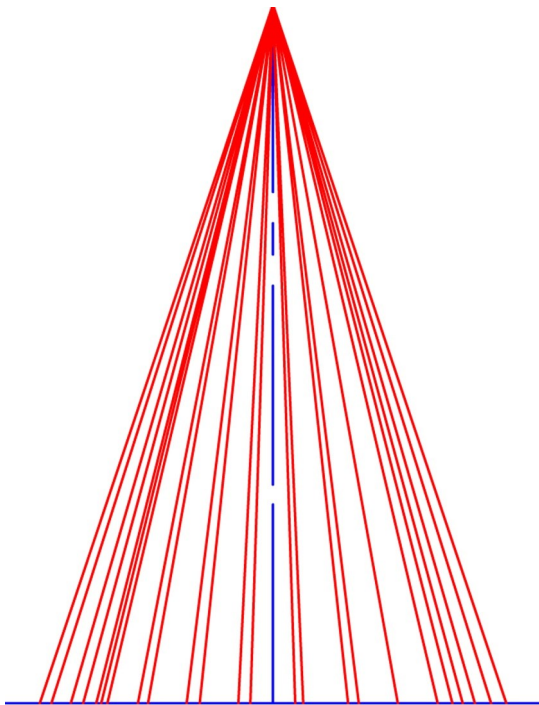

Walk across

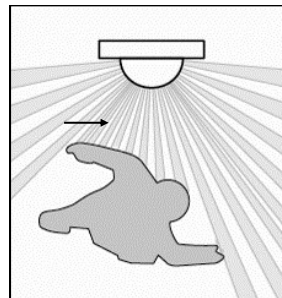

Height	Range Diameter
15m	40m
10m	26m
6m	16m
3m	9m

Walk towards

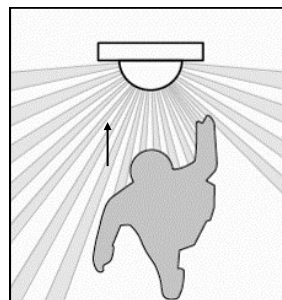

Height	Range Diameter
15m	30m
10m	20m
6m	12m
3m	8m

Alignment marks

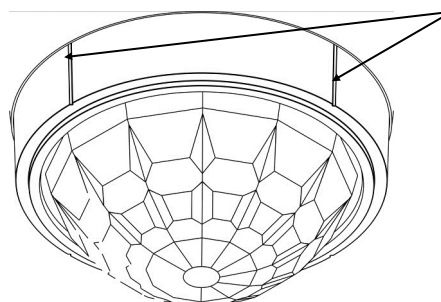

The sensor head has 4 alignment marks. These correspond to the 4 outer passive infrared sensors under the lens. Use these marks to align with aisles and corridors to ensure the best detection characteristics. See example overleaf.

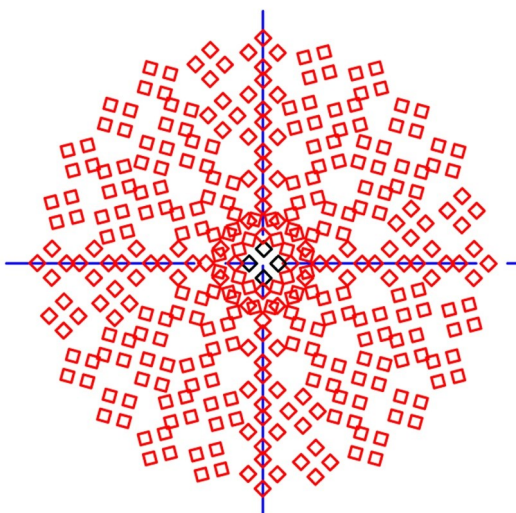

Masking

The PPAD-C-HB-DALI-ADDR includes two clip-on masking shields to allow for precise masking of the detection shape. The masks can be easily shaped to produce detection patterns suitable for applications such as aisles and corners and for narrowing the detection diameter.

Important note. Ensure all infra-red (IR) programming is completed before affixing the masking shields to the detector.

The masking shields may impair the light sensor and IR sensors by covering them. Ensure correct operation before completing commissioning.

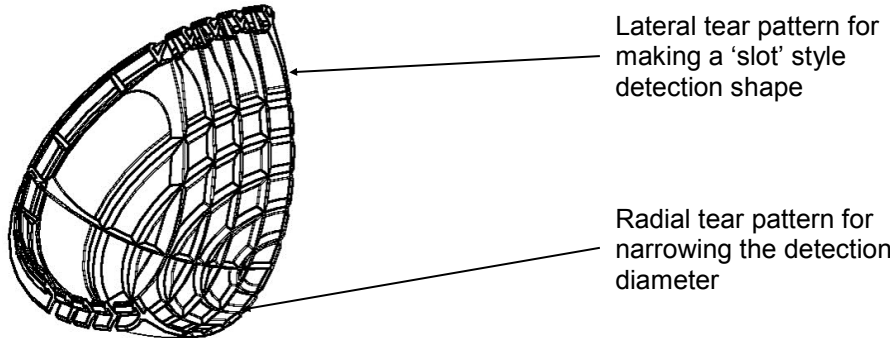

Aisles

Masking shields trimmed for aisle shaped detection

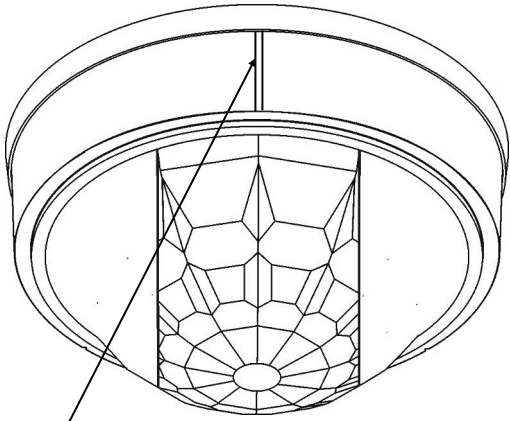

Align trimmed shields with sensor head alignment marks and aisle.

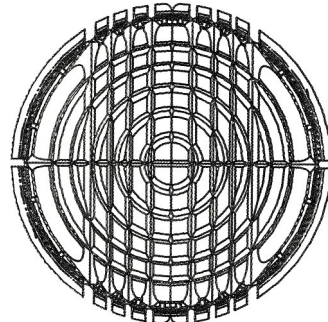

Slot number 1 2 3 4 4 3 2 1

Slot number	Masking shield % coverage
1	45%
2	32%
3	22%
4	11%

Example
 Mounting height 6m
 Trimmed to slots 2
 Aisle detection width 16m x 32% = 5.1m walk across
 12m x 32% = 3.8m walk towards

Narrow detection

Masking shields trimmed for a narrow beam of detection

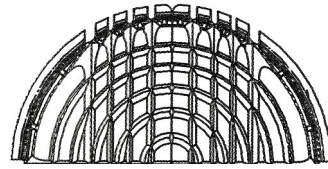
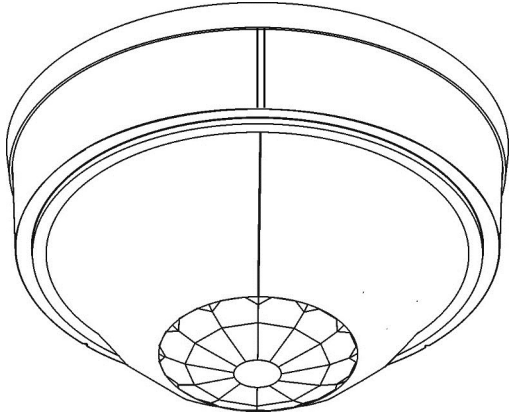

Diameter number 1 2 3 4 5 5 4 3 2 1

Diameter number	Masking shield % coverage
1	89%
2	63%
3	45%
4	32%
5	22%

Example
 Mounting height 15m
 Trimmed to diameter 3
 Detection diameter 40m x 45% = 18m walk across
 30m x 45% = 13.5m walk towards

Installing the PIR Detector

Choosing a Suitable Location

The PIR Detector is designed to be ceiling mounted and must satisfy the following criteria:

- Avoid positioning the unit where direct sunlight may enter the sensor element.
- Do not site the sensor within 1m of any lighting, forced air heating or ventilation.
- Do not fix the sensor to an unstable or vibrating surface.
- Position the sensor so that the occupants of the room fall inside the detection zone. Note that the detection zone illustrated is based on a recommended mounting height of 2.8m. A lower height will decrease the overall size of the detection zone.

Mounting Methods

The Detector is designed to be mounted using either:

- Flush fixing (recommended), or
- Surface fixing, using the optional Surface Mounting Box (part no. MPAD-C-SURFACE BOX).

Both methods are illustrated in below.

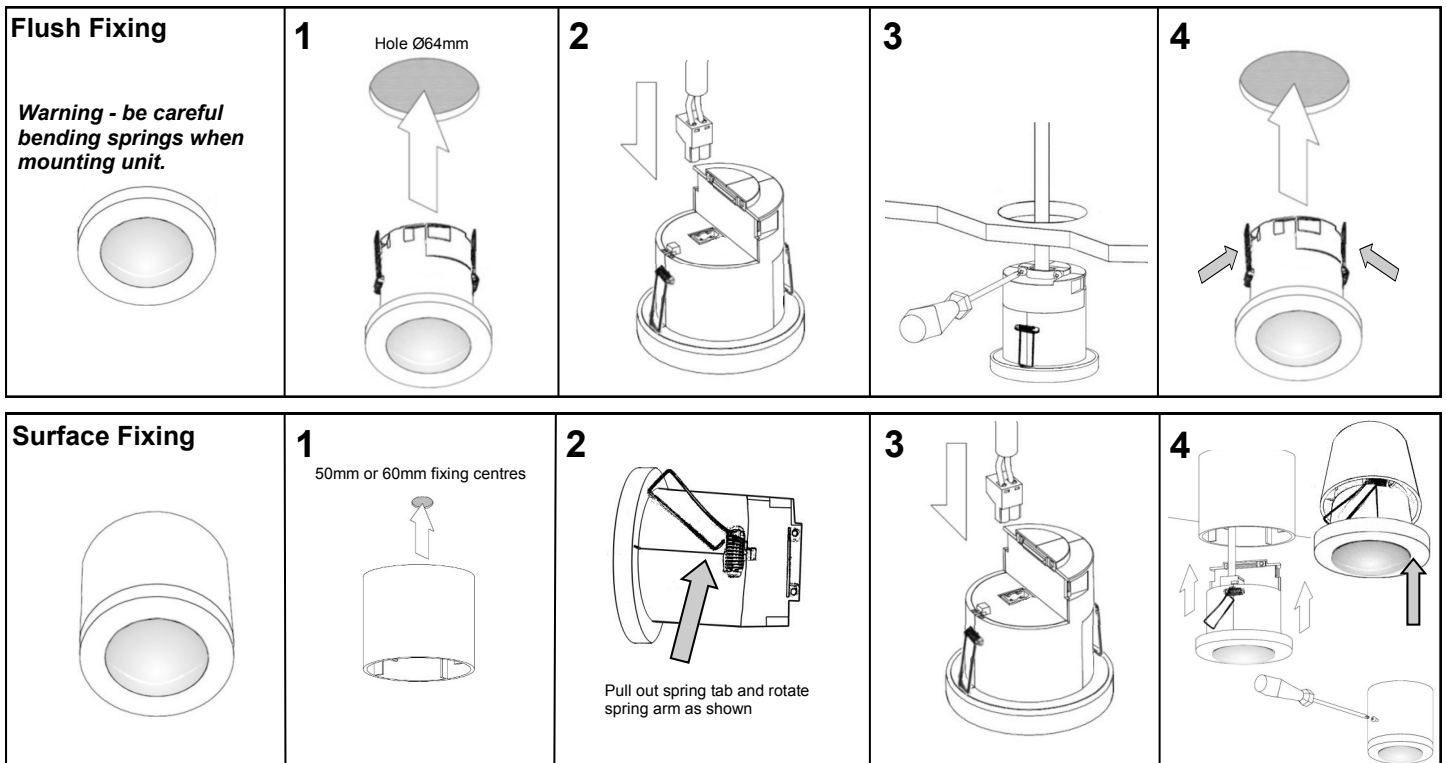

Technical data

Dimensions	See diagrams on page 1
Weight	0.10kg
Supply Voltage	9.5VDC—22.5VDC via DALI
Supply Current	8mA
Terminal Capacity	2.5mm ² (solid or stranded)
Material (casing)	Flame retardant ABS and PC/ABS
IP rating	40 without gasket. 65 with included gasket.
Compliance	EMC-2014/30/EU LVD-2014/35/EU



Powering Business Worldwide

Eaton Lighting Systems

Usk House, Lakeside
Llantarnam Park,
Cwmbran, NP44 3HD, UK
Tel: +44 (0)1633 838088
Fax: +44 (0)1633 867880
lightingcontrolsolutions@eaton.com
www.eatonlightingsystems.com