

- de MONTAGEANLEITUNG
- en MOUNTING INSTRUCTIONS
- fr INSTRUCTIONS DE MONTAGE
- it ISTRUZIONI DI MONTAGGIO
- es INSTRUCCIONES DE MONTAJE
- nl MONTAGEHANDLEIDING

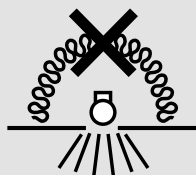

## SONNOS

10172493 / II 20

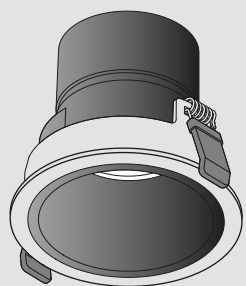
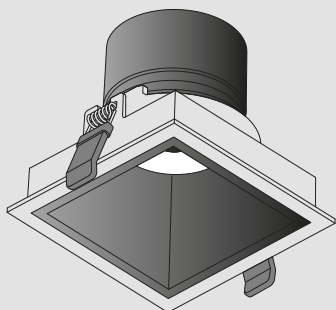

SNS Q C01 ...  
SNS Q C03 ...  
SNS ACT Q C03 ...  
SNS R C01 ...  
SNS R C03 ...  
SNS ACT R C03 ...  
SNS Q T01 ...  
SNS Q T03 ...  
SNS ACT Q T03 ...  
SNS R T01 ...  
SNS R T03 ...  
SNS ACT R T03 ...

TRILUX GmbH & Co. KG

Heidestraße  
D-59759 Arnsberg  
+49 2932 301-0  
info@trilux.de  
www.trilux.com

Lesen Sie zu Ihrer eigenen Sicherheit sorgfältig alle Hinweise und Montageschritte.  
Bewahren Sie die Anleitung für Wartungs- oder Demontearbeiten auf.



Der elektrische Anschluss darf nur von fachkundigem Personal durchgeführt werden, das hierfür ausgebildet und befugt ist.



#### WARNUNG - Gefahr eines elektrischen Schlages!

- Arbeiten Sie niemals bei anliegender Spannung an der Leuchte.

#### Die Lichtquelle (LED-Modul) dieser Leuchte ist nicht ersetzbar.

- Wenn die Lichtquelle ihr Lebensdauerende erreicht hat, ersetzen Sie die gesamte Leuchte.
- LED-Modul: **Risikogruppe 1**



#### Schutz vor Überhitzung und Brandgefahr

- Decken Sie die Leuchte nicht mit Dämmmaterial ab.
- Keine Leitungen auf die Leuchten legen.

#### Wichtige Hinweise zu elektronischen Betriebsgeräten (EVG)

- Eine Neutralleiterunterbrechung im Drehstromkreis führt zu Überspannungsschäden in der Beleuchtungsanlage. Öffnen Sie die Neutralleiter-Trennklemme nur spannungsfrei und schließen Sie Neutralleiter-Trennklemme vor Wiedereinschalten.
- Die maximal zulässige Umgebungstemperatur  $t_a$  der Leuchte darf nicht überschritten werden. Eine Überschreitung reduziert die Lebensdauer, im Extremfall droht ein Frühausfall der Leuchte.
- Legen Sie die Anschlussleitungen für Steuereingänge dimmbarer EVG (1-10 V, DALI, etc.) 230 V netzspannungsfest (Basisisolierung) aus.



#### BESTIMMUNGSGEMÄSSE VERWENDUNG

- Bestimmt für Innenräume mit einer Umgebungstemperatur von:  $t_a$  25 °C
- Schutzklasse: II
- Schutzart: IP20
- Geeignet für Netzweiterleitung.
- **Sonnos ... T01... nicht** geeignet für Netzweiterleitung.



#### Entsorgung von Elektro- und Elektronik-Altgeräten

- Sammeln und Entsorgen Sie Elektro- und Elektronik-Altgeräte am Ende ihrer Lebensdauer immer getrennt. Holen Sie sich im Zweifel Auskunft zur umweltgerechten Entsorgung bei der örtlichen Kommunalbehörde oder speziellen Entsorgungsfachbetrieben ein.
- Wichtige Informationen zur Energieeffizienz von TRILUX-Leuchten sowie zur Leuchtenwartung und -entsorgung finden Sie im Internet: [www.trilux.com/eg245](http://www.trilux.com/eg245)

For your own safety, read all instructions and mounting steps carefully.  
Keep the instructions for maintenance or disassembly work.



The electrical connection shall only be carried out by professional personnel trained and authorised for this purpose.



#### WARNING - risk of electric shock!

- Never work on the luminaire with voltage applied.

#### The light source (LED module) of this luminaire cannot be replaced.

- When the light source has reached the end of its service life, replace the entire luminaire.
- LED module: **risk group 1**.



#### Protection against overheating and fire hazard

- Do not cover the luminaire with insulating material.
- Do not place any cables on the luminaire.

#### Important information on electronic control gear units (ECG)

- A neutral conductor interruption in the three-phase circuit leads to overvoltage damage in the lighting system. Only open the neutral conductor isolating terminal in de-energized state, and close the neutral conductor isolating terminal before switching on again.
- Do not exceed the maximum permissible ambient temperature  $t_a$  of the luminaire. Exceeding this limit reduces the service life and in extreme cases there is a risk of premature failure of the luminaire.
- Lay out the connection cables for the control inputs of dimmable ECGs (1-10 V, DALI etc.) 230 V mains voltage-proof (basic insulation).



#### INTENDED USE

- Intended for indoor rooms with an ambient temperature of:  $t_a$  25 °C
- Safety class: II
- Protection rating: IP20
- Suitable for mains through-wiring.
- **Sonnos ... T01... not** suitable for mains through-wiring.



#### Disposal of waste electrical and electronic equipment

- Always collect and dispose of old electrical and electronic equipment separately at the end of its service life. In case of doubt, seek information about environmentally-compliant waste disposal from your local district authority or special waste disposal companies.
- For important information on the energy efficiency of TRILUX luminaires and on maintaining and disposing of luminaires, see the internet at: [www.trilux.com/ec245](http://www.trilux.com/ec245)

Pour votre propre sécurité, lisez attentivement toutes les remarques et étapes de montage. Conservez ces instructions pour des travaux d'entretien ou de démontage.



Le raccordement électrique ne peut être effectué que par un personnel compétent, dûment formé et autorisé à effectuer de telles opérations.



#### AVERTISSEMENT : risque d'électrocution!

- Ne travaillez jamais sur un luminaire sous tension.

La source de lumière (module LED) de ce luminaire ne peut être remplacée.

- Lorsque la source de lumière a atteint la fin de sa durée de vie, remplacez tout le luminaire.
- Module LED : **groupe de risques 1**



#### Protection contre la surchauffe et les risques d'incendie

- Ne recouvrez pas le luminaire de matériau isolant.
- Ne pas poser de fileries sur le luminaire.

#### Remarques importantes concernant les ballasts électroniques (EVG)

- Une interruption du conducteur neutre dans le circuit de courant triphasé entraîne des dommages de surtension dans l'installation d'éclairage. Ouvrez la borne de coupure du conducteur neutre lorsque l'installation est hors tension et fermez-la avant la remise sous tension.
- Ne pas dépasser la température ambiante maximale admissible  $t_a$  du luminaire. Un dépassement réduit la durée de vie et peut, au pire, entraîner une défaillance prématurée du luminaire.
- Dimensionnez les câbles d'alimentation pour les entrées de commande de ballasts électroniques dimmables (1 à 10 V, DALI, etc.) afin qu'ils supportent une tension de secteur de 230 V (isolation de base).



#### UTILISATION CONFORME À L'USAGE PRÉVU

- Conçu pour des espaces intérieurs à la température ambiante de  $t_a$  25 °C
- Classe électrique: **II**
- Indice de protection: **IP20**
- Convenant à un repiquage secteur.
- **Sonnos...T01... ne convenant pas** à un repiquage secteur.



#### Élimination de DEEE

- À la fin de leur durée de vie, collectez et éliminez toujours les DEEE de manière sélective. Si vous avez des doutes sur une élimination sans danger pour l'environnement, demandez auprès des autorités locales ou d'entreprises de valorisation.
- Vous avez la possibilité de consulter des informations importantes concernant l'efficacité énergétique des luminaires TRILUX ainsi que l'entretien et l'élimination des luminaires sur le site Internet: [www.trilux.com/ec245](http://www.trilux.com/ec245)

Per la propria sicurezza, leggere con attenzione tutti gli avvisi e le descrizioni delle varie tappe della procedura di montaggio. Conservare le istruzioni per poterle consultare al momento di eseguire lavori di manutenzione e smontaggio.



L'allacciamento elettrico deve essere realizzato da personale specializzato a ciò addestrato e autorizzato.



#### AVVERTENZA - Pericolo di scarica elettrica!

- Mai lavorare sull'apparecchio in presenza di tensione.

La sorgente luminosa (modulo LED) di questo apparecchio non è sostituibile.

- Quando la sorgente luminosa è arrivata al termine della sua durata utile, sostituire l'intero apparecchio.
- Modulo LED: **gruppo di rischio 1**



#### Protezione da surriscaldamento e pericolo di incendio

- Non coprire l'apparecchio con materiale isolante.
- No poner los cables sobre la luminaria.

#### Avvisi importanti sui reattori elettronici

- Un'interruzione del conduttore di neutro nel circuito trifase provoca danni da sovratensioni nell'impianto di illuminazione. Aprire il morsetto di sezionamento del conduttore di neutro solo senza tensione e chiuderlo prima del reinserimento.
- La massima temperatura ambiente ammissibile ( $t_a$ ) dell'apparecchio non deve essere oltrepassata. Questo ridurrebbe altrimenti la durata utile e, nel caso estremo, si rischierebbe un guasto precoce dell'apparecchio.
- Realizzare i cavi di allacciamento per ingressi di comando di reattori elettronici dimmerabili (1-10 V, DALI ecc.) in modo che presentino rigidità dielettrica con tensione di rete di 230 V (isolamento base)



#### IMPIEGO SECONDO DESTINAZIONE

- Destinato all'impiego in interni con una temperatura ambiente ( $t_a$ ) di 25 °C
- Classe di isolamento: **II**
- Grado di protezione: **IP20**
- Idoneo per instradamento di rete.
- **Sonnos...T01... non idoneo per instradamento di rete.**



#### Smaltimento di rifiuti di apparecchiature elettriche ed elettroniche

- Alla fine del loro periodo di durata utile, raccogliere e smaltire i rifiuti di apparecchiature elettriche ed elettroniche sempre in modo differenziato. Nel dubbio, si raccomanda di chiedere informazioni su uno smaltimento conforme alla normativa ambientale presso le autorità municipali del posto o aziende specializzate nello smaltimento di rifiuti.
- Per informazioni importanti sull'efficienza energetica degli apparecchi TRILUX e sulla manutenzione e smaltimento di apparecchi si rimanda: [www.trilux.com/ec245](http://www.trilux.com/ec245)

Para su propia seguridad, lea cuidadosamente todos los avisos y pasos de montaje. Guarde las instrucciones para los trabajos de mantenimiento y desmontaje.



La conexión eléctrica debe ser realizada exclusivamente por personal especializado que ha sido formado y autorizado para este fin.



#### ADVERTENCIA - ¡Riesgo de descarga eléctrica!

- Nunca realice trabajos en la luminaria si esta tiene tensión.

La fuente de luz (módulo LED) de esta luminaria no puede sustituirse.

- Al final de la vida útil de la fuente de luz, usted debe sustituir toda la luminaria.
- Módulo LED: **grupo de riesgo 1**



#### Protección contra sobrecalentamiento y riesgo de incendio

- No cubra la luminaria con material aislante.
- No poner los cables sobre la luminaria.

#### Avisos importantes en lo referente a los balastos electrónicos (EVGs)

- Una interrupción del conductor neutro en el circuito de corriente trifásica provoca daños por sobretensión en la instalación de iluminación. Solamente abra el borne desconectador del conductor neutro cuando este esté desconectado de la tensión y cierre el borne desconectador del conductor neutro antes de la reconexión.
- No debe sobrepasarse la temperatura ambiente máxima admitida  $t_a$  de la luminaria. Al sobrepasarla, la vida útil se reduce y, en un caso extremo, puede provocarse un fallo prematuro de la luminaria.
- Los cables de conexión para las entradas de control de los balastos electrónicos (EVGs) regulables (1-10 V, DALI, etc.) 230 V deben ser resistentes a la tensión de red (aislamiento básico).



#### USO CONFORME

- Destinado para espacios interiores con una temperatura ambiente:  $t_a$  de 25 °C
- Clase de protección: II
- Grado de protección: IP20
- Apto para el cableado suplementario.
- **Sonnos...T01... no** apto para el cableado suplementario.



#### Eliminación de dispositivos eléctricos y electrónicos antiguos

- Recoja y elimine los dispositivos eléctricos y electrónicos antiguos siempre por separado al final de su vida útil. En caso de duda, consulte las autoridades comunales o las empresas especializadas en eliminación de residuos para tener información sobre la eliminación respetuosa con el medio ambiente.
- En [www.trilux.com/ec245](http://www.trilux.com/ec245) encontrará información importante sobre la eficiencia energética de las luminarias de TRILUX y sobre su mantenimiento y eliminación.

Voor uw eigen veiligheid is het belangrijk dat u alle opmerkingen en montagestappen zorgvuldig leest.

Bewaar de handleiding voor latere onderhouds- of demontagewerkzaamheden.



De elektrische aansluiting moet worden uitgevoerd door vakkundig personeel, dat hiervoor opgeleid en bevoegd is.



#### WAARSCHUWING - Gevaar voor een elektrische schok!

- Werk nooit aan de armatuur terwijl deze onder spanning staat.

De lichtbron (LED-module) van deze armatuur kan niet vervangen worden.

- Als de lichtbron het einde van haar levensduur bereikt heeft, dient de hele armatuur vervangen te worden.
- LED-module: **risicogroep I**



#### Beveiliging tegen oververhitting en brandgevaar

- Bedek de armatuur niet met isolatiemateriaal.
- Geen kabels op de armaturen leggen.

#### Belangrijke aanwijzingen voor elektronische voorschakelapparaten (EVSA)

- Een onderbreking van de nulleider in de draaistroomkring veroorzaakt schade door overspanning in de verlichtingsinstallatie. Open de nulleider-nullem alleen als de kring spanningsvrij is en sluit de nulleider-nullem alvorens de spanning weer in te schakelen.
- De maximaal toelaatbare omgevingstemperatuur ( $t_a$ ) van de armatuur mag niet overschreden worden. Overschrijding van de maximumtemperatuur kan de levensduur van de armatuur verkorten en in extreme gevallen zelfs leiden tot vroegtijdige uitval.
- Leg aansluitleidingen voor de sturingen van de dimbare EVSA (1...10 V, DALI enz.) 230 V die geschikt zijn voor de netspanning (basisisolatie).



#### BEDOELD GEBRUIK

- Bedoeld voor binnengebruik bij een omgevingstemperatuur van:  $t_a$  25 °C
- Beschermingsklasse: II
- Beschermklasse: IP20
- Geschikt voor doorlussen van de voeding.
- **Sonnos...T01... niet** geschikt voor doorlussen van de voeding



#### Afgedankte elektrische en elektronische apparaten verwijderen

- Afgedankte elektrische en elektronische apparaten moeten altijd gescheiden van het andere afval worden bewaard en afgevoerd. Vraag in geval van twijfel aan de plaatselijke bevoegde openbare dienst of een gespecialiseerd afvalverwerkingsbedrijf hoe u deze apparaten afdankt met respect voor het milieu.
- Belangrijke informatie over de energie-efficiëntie van TRILUX-armaturen evenals informatie over onderhoud en afvoer van armaturen vindt u terug op het internet: [www.trilux.com/ec245](http://www.trilux.com/ec245)

- de Übersicht
- en Overview
- fr Aperçu
- it Tabella
- es Resumen
- nl Overzicht

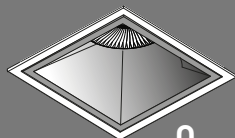

... Q ...



... R ...









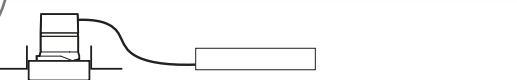

- |                 |                            |              |                |
|-----------------|----------------------------|--------------|----------------|
| de Vormontage   | de Elektrischer Anschluss  | de Montage   | de Demontage   |
| en Pre-assembly | en Electrical connection   | en Mounting  | en Disassembly |
| fr Prémontage   | fr Raccordement électrique | fr Montage   | fr Démontage   |
| it Premontaggio | it Collegamento elettrico  | it Montaggio | it Smontaggio  |
| es Premontaje   | es Conexión eléctrica      | es Montaje   | es Desmontaje  |
| nl Voormontage  | nl Elektrische verbinding  | nl Montage   | nl Demontage   |

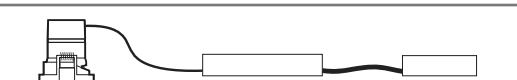
Page

Page

Page

Page

		SNS Q T01 ... SNS R T01 ...	- 15	15 20	20 29	29 29
		SNS Q T03 ... SNS R T03 ...	16 16	20 20	29 29	29 29
		SNS ACT Q T03 ... SNS ACT R T03 ...	17 17	20 20	29 29	29 29
		SNS Q C01 ... SNS R C01 ...	16 16	22 22	30 30	30 30
		SNS Q C03 ... SNS R C03 ...	- 16	16 22	30 30	30 30
		SNS ACT Q C03 ... SNS ACT R C03 ...	- 17	22 22	30 30	30 30
		SNS... Q C01 ... IP54 SNS... R C01 ... IP54	- -	- 22 + 28	30 30	30 30
		SNS... Q C03 ... IP54 SNS... R C03 ... IP54	- -	- 22 + 28	30 30	30 30
		SNS... Q T03 W SNS... R T03 W	- -	- 24	29 29	29 29
		SNS... Q C03 W SNS... R C03 W	- -	- 26	30 30	30 30
		SNS... R C01 R ... SNS... R C03 R ...	- -	- 27	30 30	30 30



Type  
 SNS Q T01 ... (+... ZPF-T ...)  
 SNS R T01 ... (+... ZPF-T ...)

TRILUX	≈ kg
Xxxx XXX XX	0,5
 CE	0,5

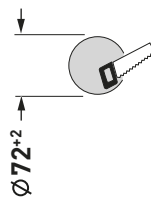
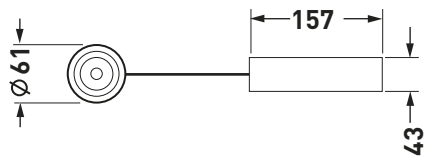
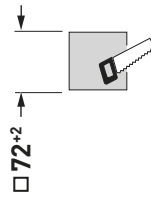
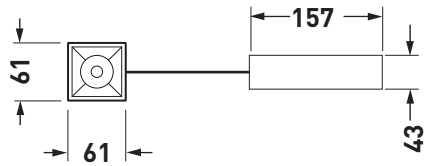
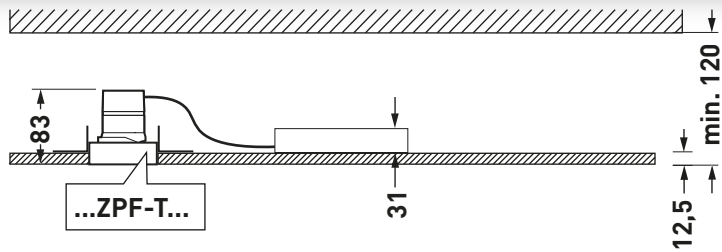

Type  
 SNS Q T03 ... (+... ZPF-T ...)  
 SNS R T03 ... (+... ZPF-T ...)  
 SNS ACT Q T03 ... (+... ZPF-T ...)  
 SNS ACT R T03 ... (+... ZPF-T ...)

TRILUX	≈ kg
Xxxx XXX XX	0,7
 CE	0,7
	1,2
	1,2

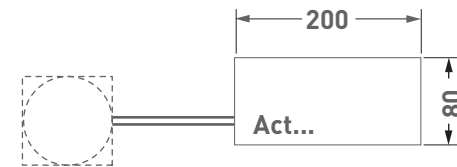
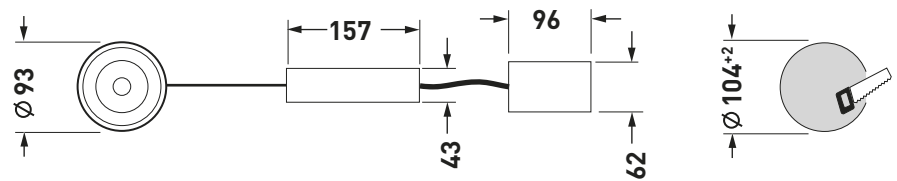
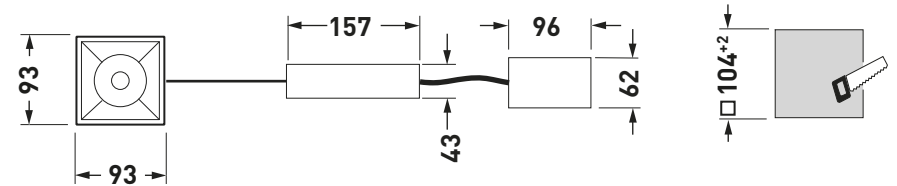
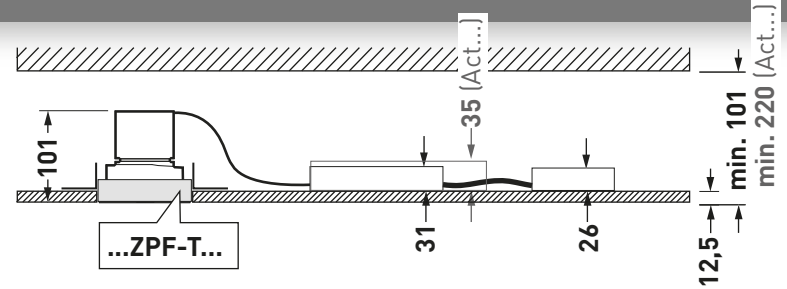

Type  
 SNS Q C01 ...  
 SNS R C01 ...

TRILUX	≈ kg
Xxxx XXX XX	0,4
 CE	0,4

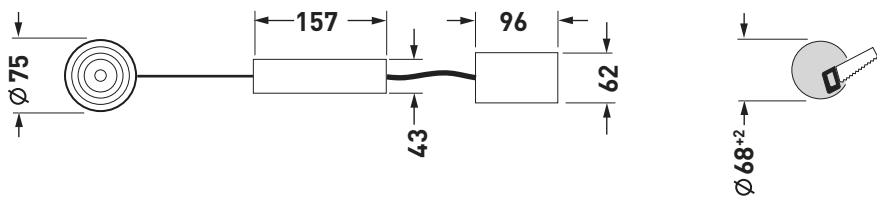
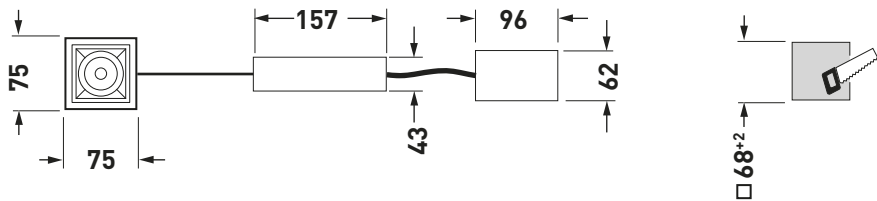
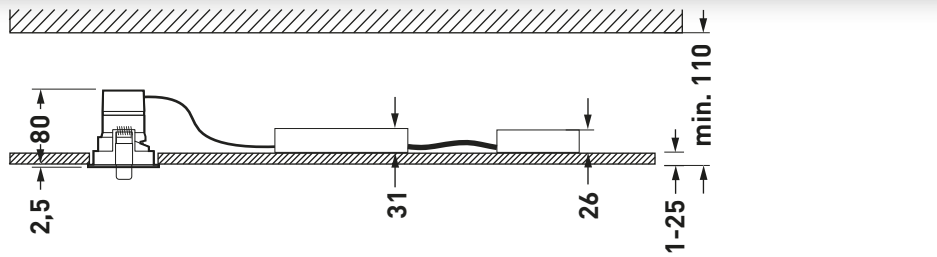

Type  
 SNS Q C03 ...  
 SNS R C03 ...  
 SNS ACT Q C03 ...  
 SNS ACT R C03 ...

TRILUX	≈ kg
Xxxx XXX XX	0,6
 CE	0,6
	1,1
	1,1

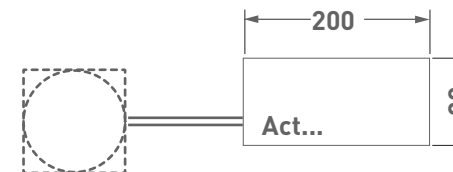
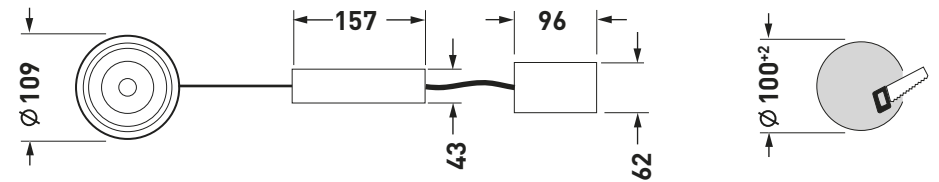
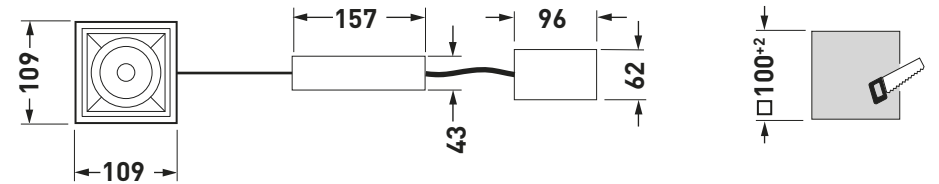
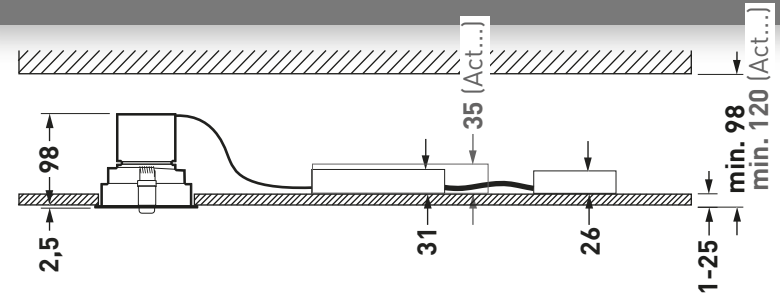



- de Sicherheitsabstände
- en Safety clearances
- fr Distances de sécurité
- it Distanze di sicurezza
- es Distancias de seguridad
- nl Veiligheidsafstanden

Type

SNS ... Q C01 ...  
 SNS ... Q C03 ...  
 SNS ... R C01 ...  
 SNS ... R C03 ...



**A = min. 91** (SNS Q/R T01/C01 ...)  
**min. 100** (SNS Q/R T01/C01 ...)

**B = min. 91** (SNS Q/R T03/C03 ...)  
**min. 150** (SNS Q/R T03/C03 ...)

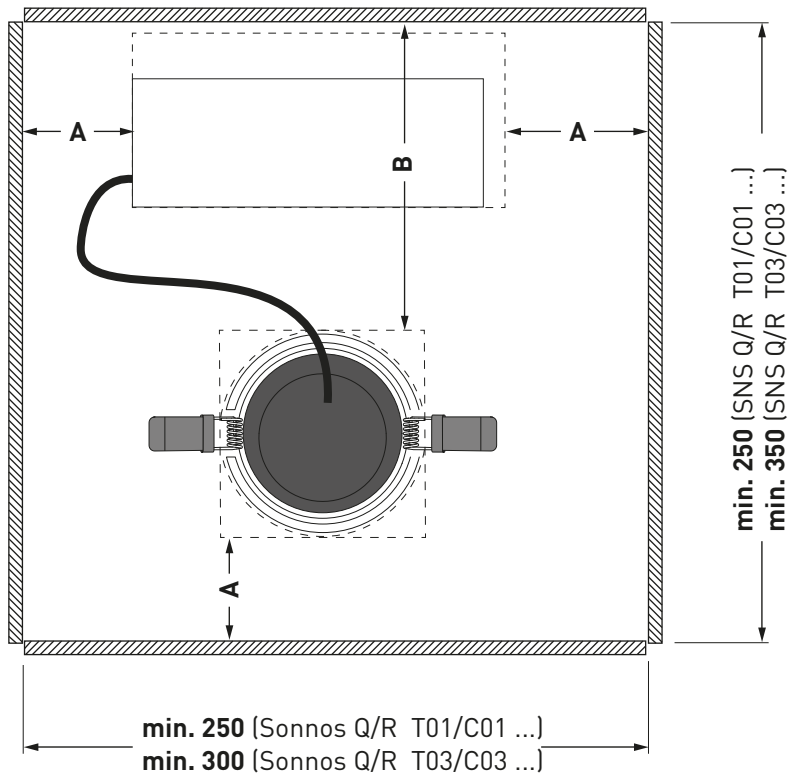
de **HINWEIS**

Montieren Sie den Connector und Reflektor mit Schutzhandschuhen.

en **NOTICE**

Assemble the connector and reflector with protective gloves.

fr **REMARQUE**

Pour le montage du connecteur et du réflecteur, utilisez des gants de protection

it **NOTA**

Montare connettore e riflettore usando guanti protettivi.

es **NOTA**

Instale el conector y el reflector con guantes de protección.

nl **OPMERKING**

Draag beschermende handschoenen bij het monteren van de connector en de reflector.

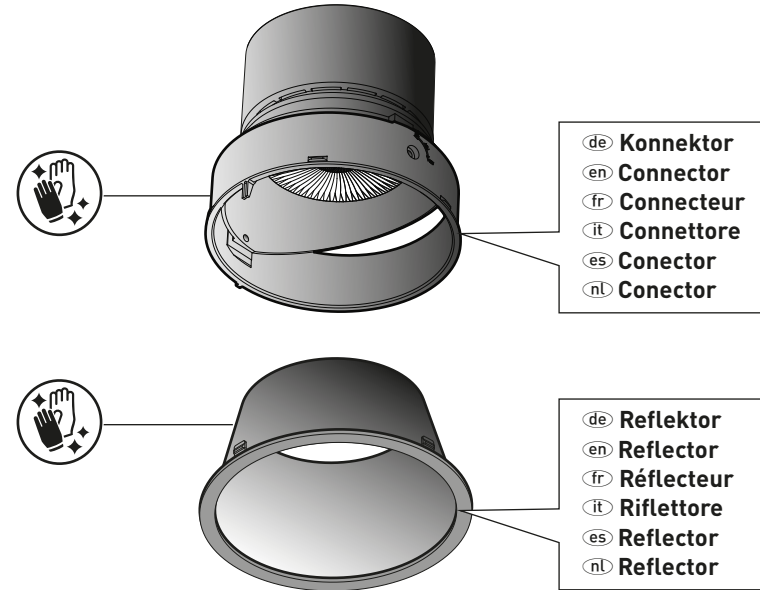





SONNOS

- de Elektrischer Anschluss
- en Electrical connection
- fr Raccordement électrique
- it Collegamento elettrico
- es Conexión eléctrica
- nl Elektrische verbinding

Type  
 SNS Q T01 ...  
 SNS R T01 ...

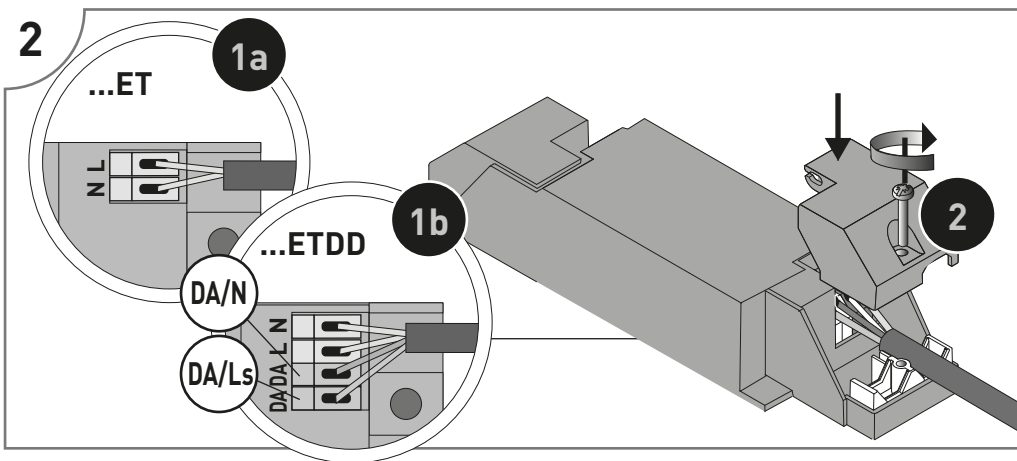
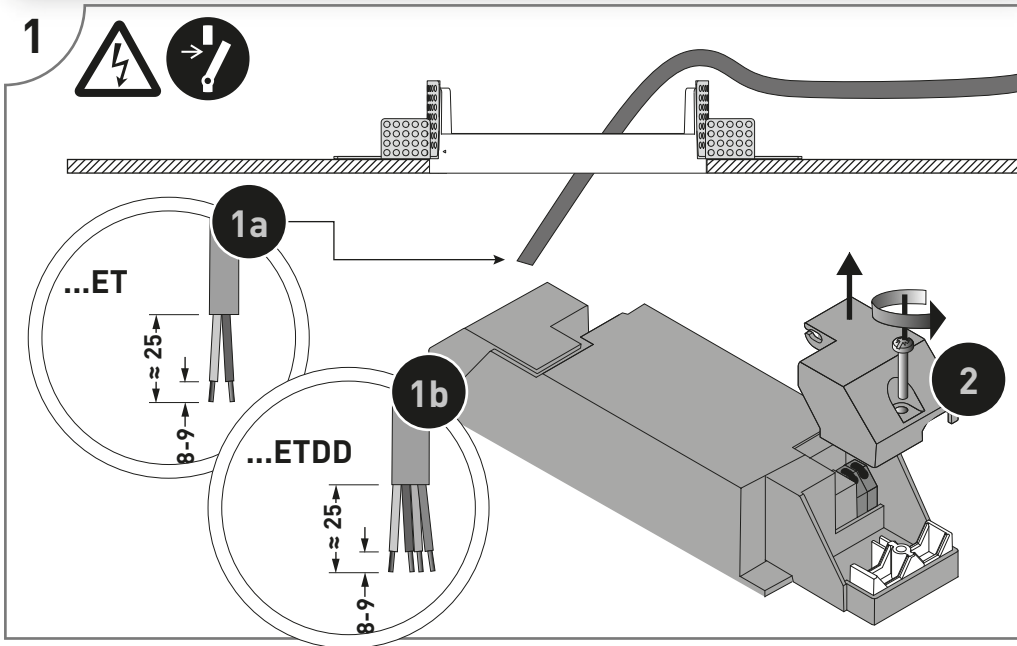
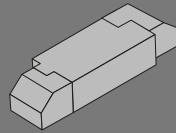

SONNOS

- de Elektrischer Anschluss
- en Electrical connection
- fr Raccordement électrique
- it Collegamento elettrico
- es Conexión eléctrica
- nl Elektrische verbinding

Type  
 SNS Q T03 ...  
 SNS R T03 ...  
 SNS Q C01 ... / C03 ...  
 SNS R C01 ... / C03 ...

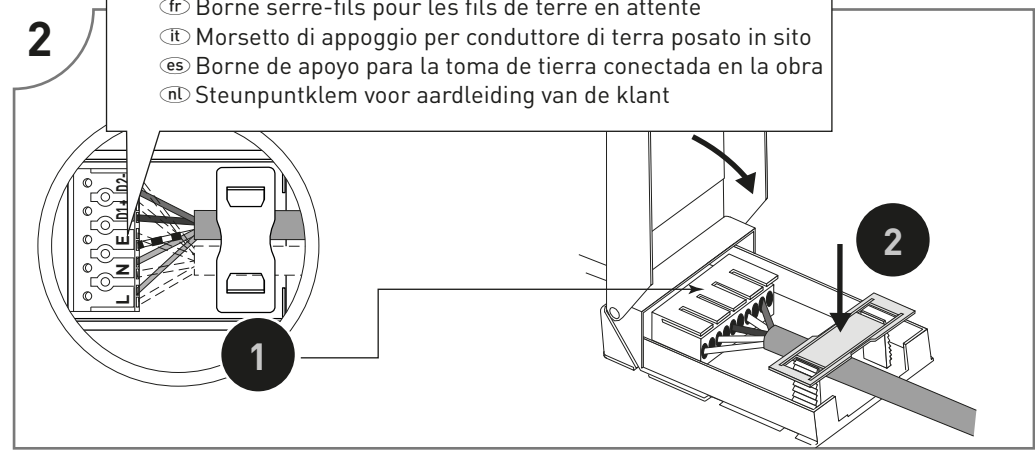
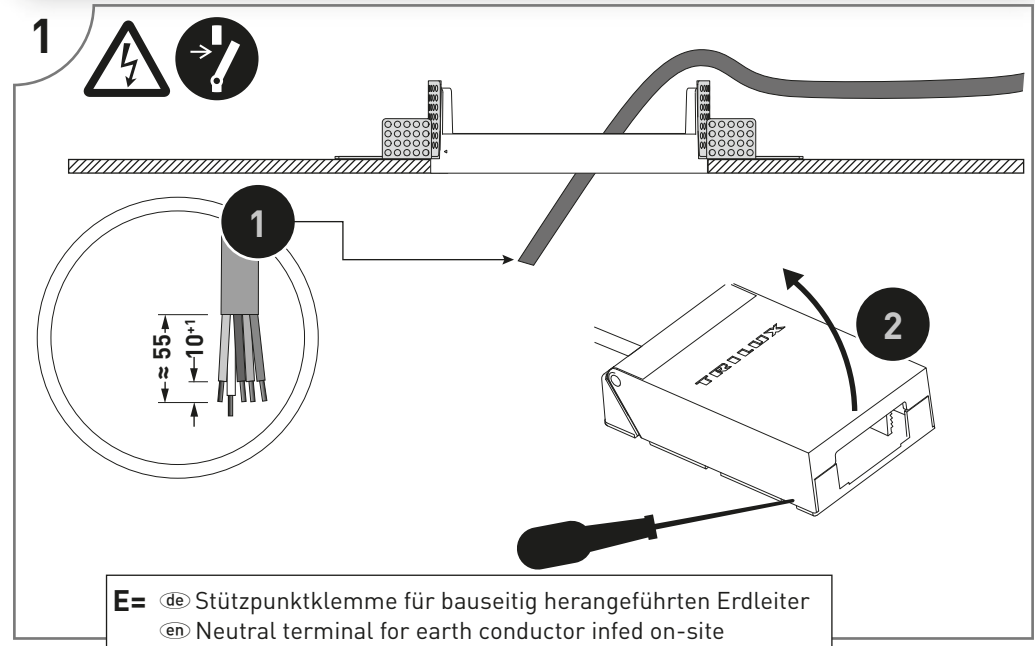
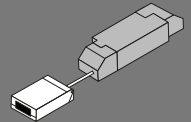

- E=**
- de Stützpunktklemme für bauseitig herangeführten Erdleiter
  - en Neutral terminal for earth conductor infed on-site
  - fr Borne serre-fils pour les fils de terre en attente
  - it Morsetto di appoggio per conduttore di terra posato in sito
  - es Borne de apoyo para la toma de tierra conectada en la obra
  - nl Steunpuntklem voor aardleiding van de klant



SONNOS

- de Elektrischer Anschluss
- en Electrical connection
- fr Raccordement électrique
- it Collegamento elettrico
- es Conexión eléctrica
- nl Elektrische verbinding

Type

- SNS ACT Q T03 ...
- SNS ACT Q C03 ...
- SNS ACT R T03 ...
- SNS ACT R C03 ...

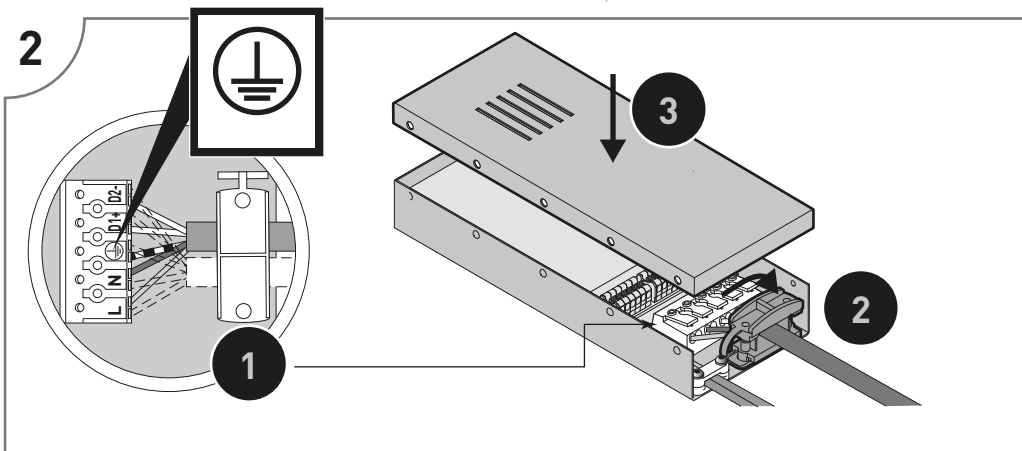
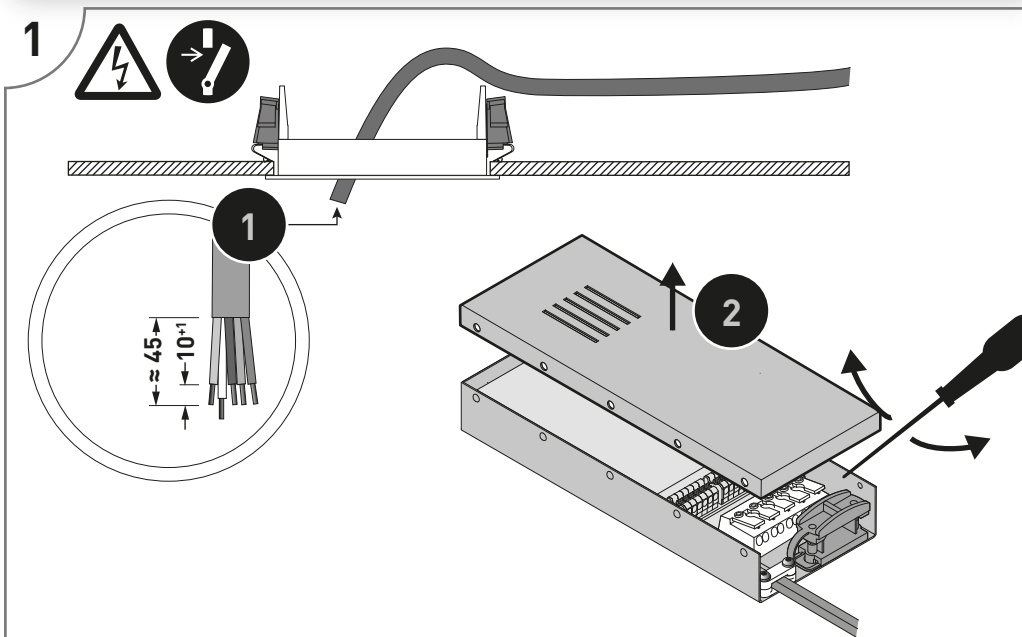
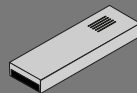

SONNOS



de **HINWEIS**

Montieren Sie den Konnektor und Reflektor mit Schutzhandschuhen.

en **NOTICE**

Assemble the connector and reflector with protective gloves.

fr **REMARQUE**

Pour le montage du connecteur et du réflecteur, utilisez des gants de protection

it **NOTA**

Montare connettore e riflettore usando guanti protettivi.

es **NOTA**

Instale el conector y el reflector con guantes de protección.

nl **OPMERKING**

Draag beschermende handschoenen bij het monteren van de connector en de reflector.

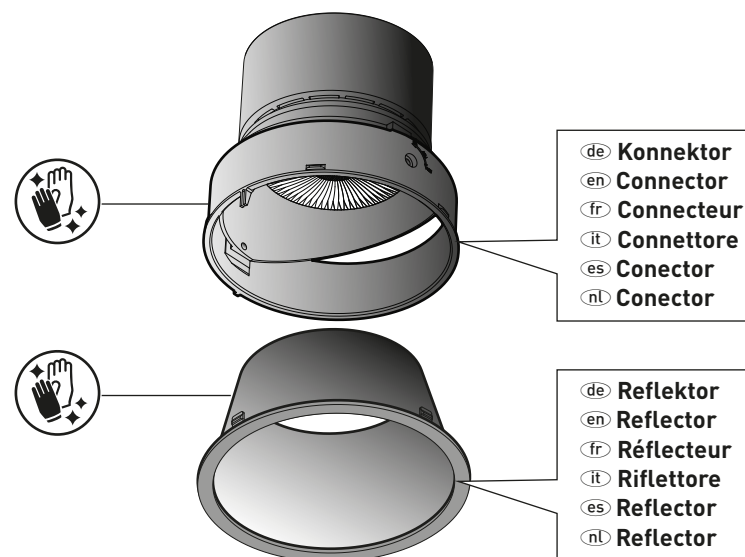



SONNOS

- de Montage
- en Mounting
- fr Montage
- it Montaggio
- es Montaje
- nl Montage

Type  
 SNS Q T01 ...  
 SNS Q T03 ...  
 SNS R T01 ...  
 SNS R T03 ...

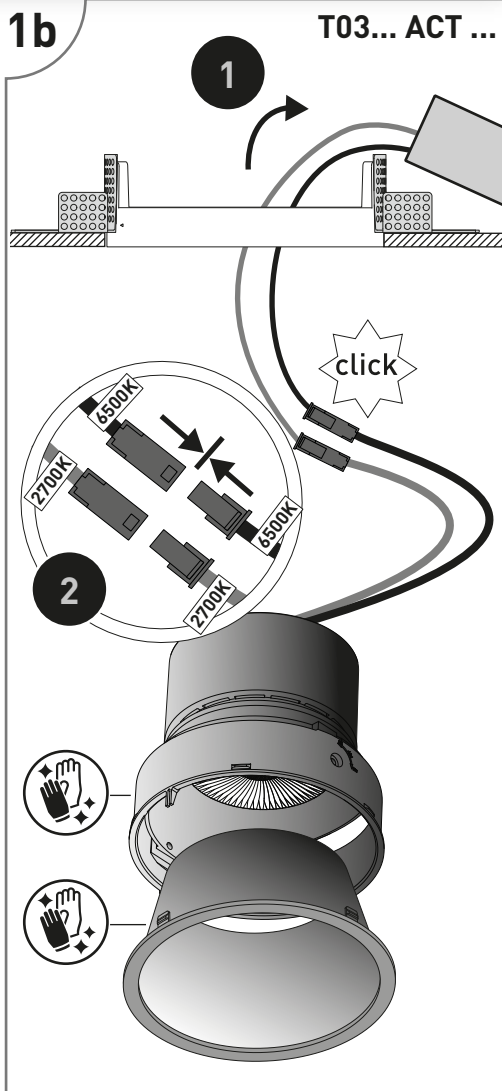
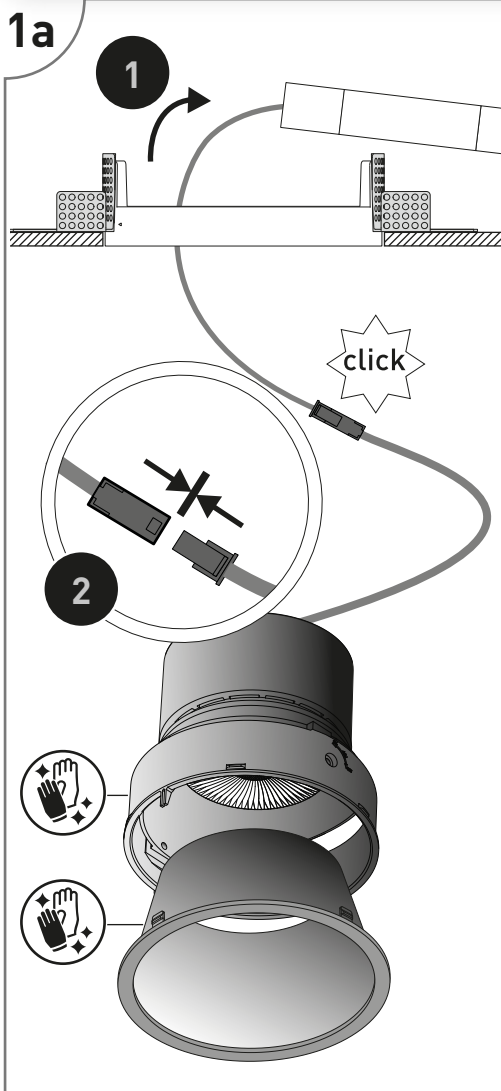

SONNOS

**2**



- de Keine Leitungen quetschen
- en Don't squeeze wire
- fr Veiller à ne pas écraser les câbles
- it Non schiacciare i cavi
- es No aplastar los cables
- nl Druk geen leidingen plat

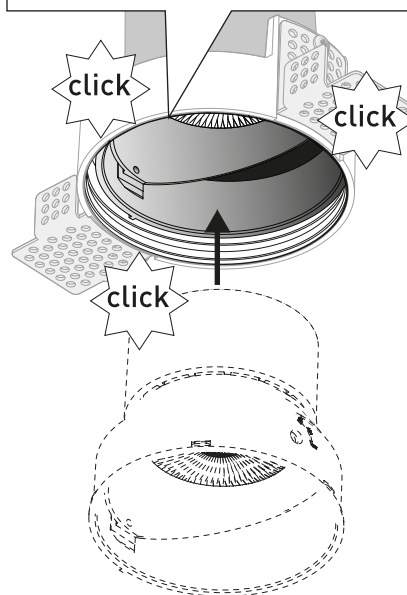

**3**

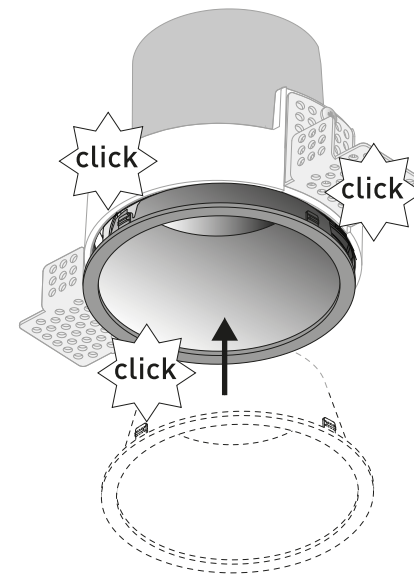

**4**

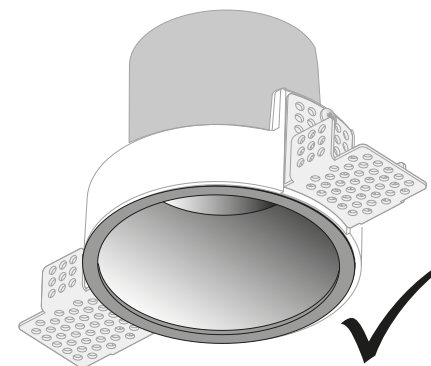



SONNOS

- de Montage
- en Mounting
- fr Montage
- it Montaggio
- es Montaje
- nl Montage

Type  
 SNS Q C01 ...  
 SNS Q C03 ...  
 SNS R C01 ...  
 SNS R C03 ...

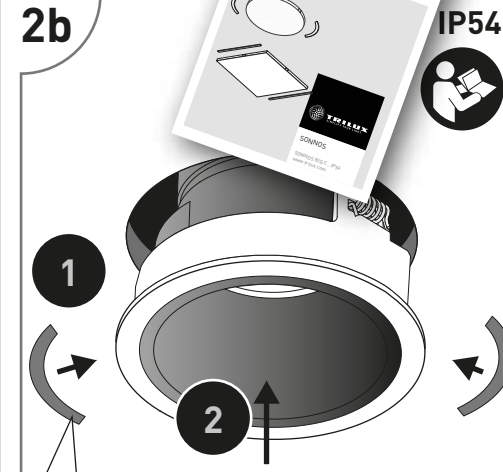
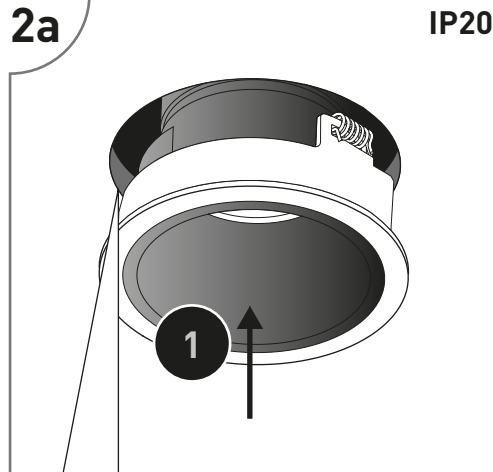
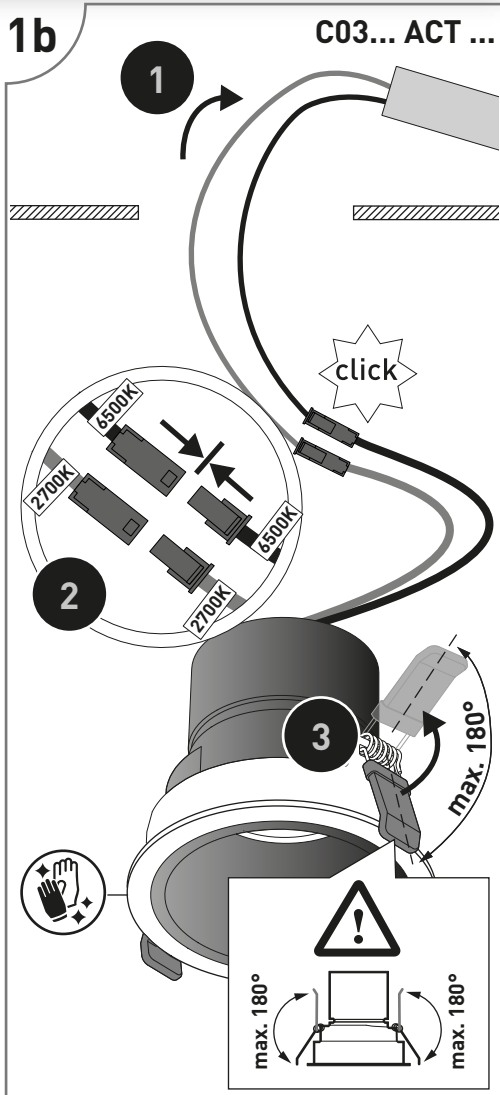
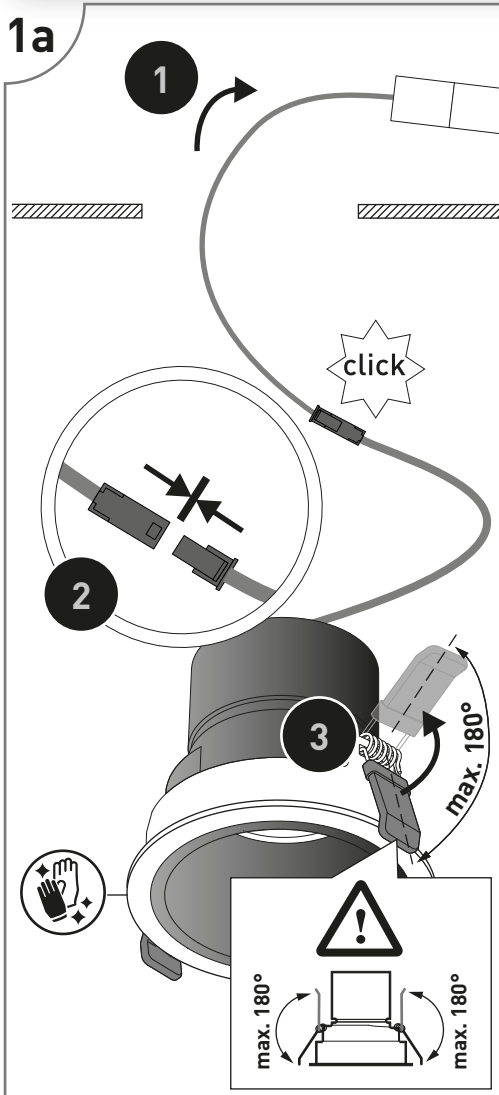

! de Keine Leitungen quetschen  
 en Don't squeeze wire  
 fr Veiller à ne pas écraser les câbles  
 it Non schiacciare i cavi  
 es No aplastar los cables  
 nl Druk geen leidingen plat

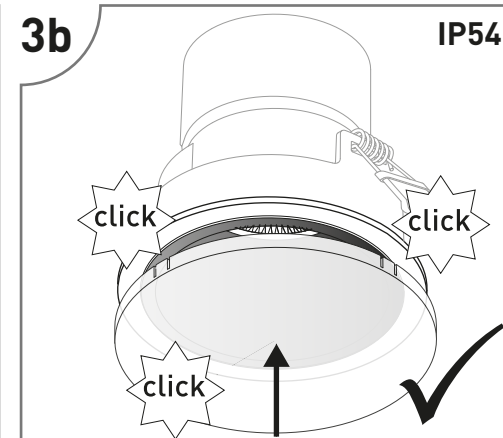
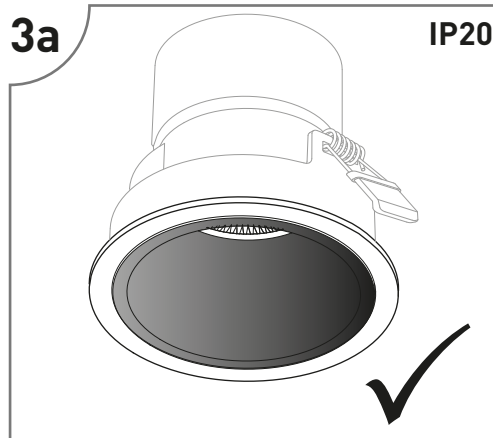
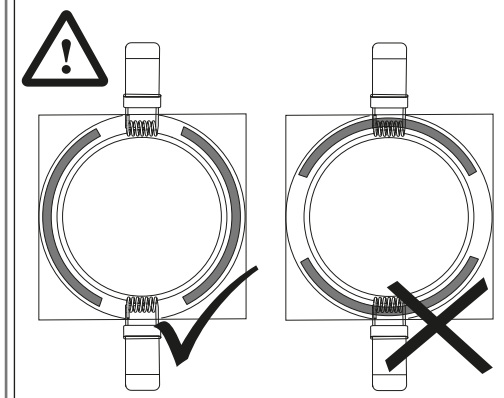



- de Montage
- en Mounting
- fr Montage
- it Montaggio
- es Montaje
- nl Montage

Type

SNS Q T03 ... WW ...

SNS R T03 ... WW ...

1

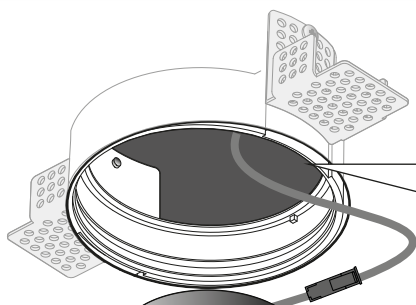

- de Keine Leitungen quetschen
- en Don't squeeze wire
- fr Veiller à ne pas écraser les câbles
- it Non schiacciare i cavi
- es No aplastar los cables
- nl Druk geen leidingen plat



- de Beachten Sie beim Einsetzen die genaue Positionierung des Reflektors (Wallwasher, SNS... Q/R T03 WW...).
- en When inserting, ensure precise positioning of the reflector (Wall-washer, SNS... Q/R T03 WW...).
- fr Lors du montage, tenez compte du positionnement exact du réflecteur (Wallwasher, SNS... Q/R T03 WW...).
- it In fase di montaggio, tenere conto dell'esatto posizionamento del riflettore (Wallwasher, SNS... Q/R T03 WW...).
- es Para la instalación tenga en cuenta el posicionamiento exacto del reflector (Wallwasher, SNS... Q/R T03 WW...).
- nl Let bij de inbouw op de correcte positionering van de reflector (Wallwasher, SNS... Q/R T03 WW...).



2

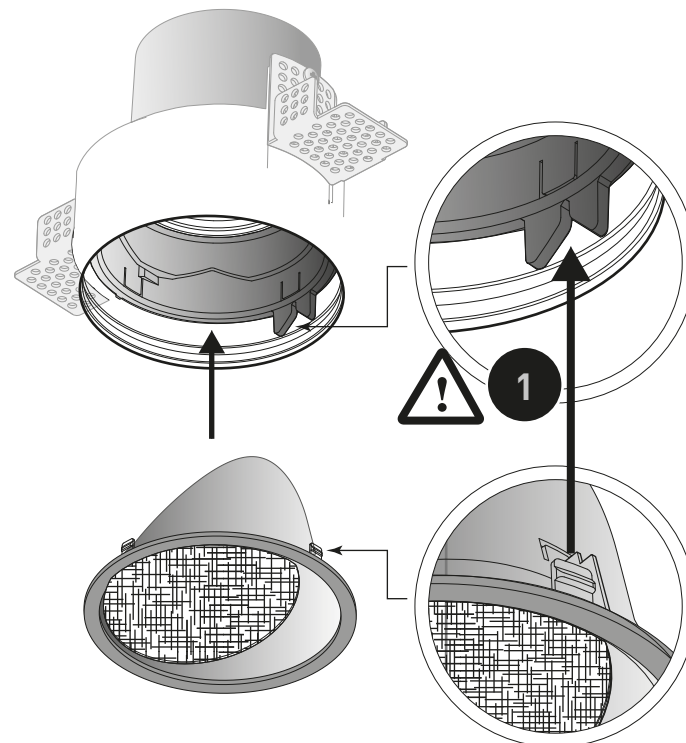

3

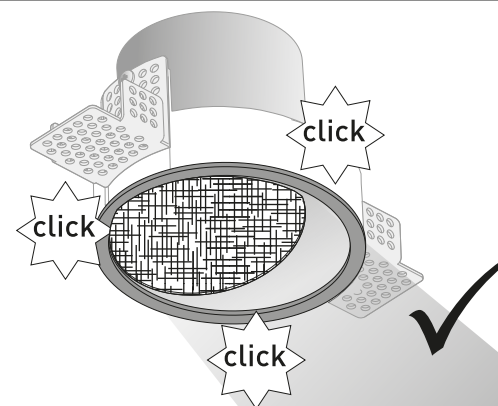



SONNOS

- de Montage
- en Mounting
- fr Montage
- it Montaggio
- es Montaje
- nl Montage

Type

SNS ... Q C03 ... WW ...

SNS ... R C03 ... WW ...

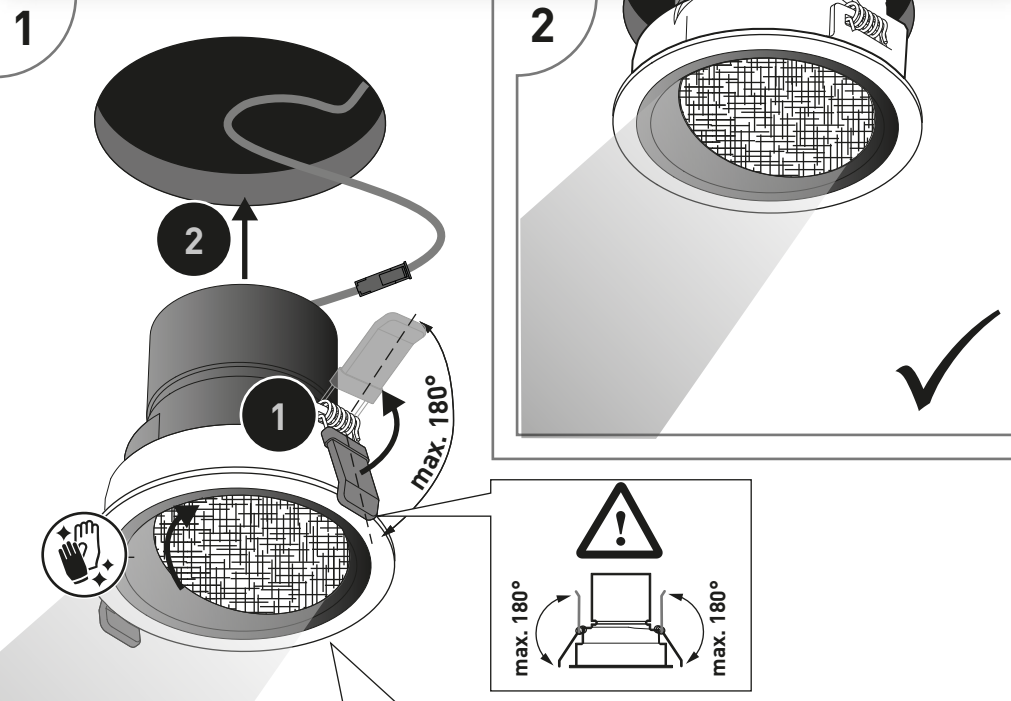

- de Beachten Sie beim Einsetzen die genaue Positionierung des Reflektors (Wallwasher, **SNS... Q/R C03 WW...**).
- en When inserting, ensure precise positioning of the reflector (Wall-washer, **SNS... Q/R C03 WW...**).
- fr Lors du montage, tenez compte du positionnement exact du réflecteur (Wallwasher, **SNS... Q/R C03 WW...**).
- it In fase di montaggio, tenere conto dell'esatto posizionamento del riflettore (Wallwasher, **SNS... Q/R C03 WW...**).
- es Para la instalación tenga en cuenta el posicionamiento exacto del reflector (Wallwasher, **SNS... Q/R C03 WW...**).
- nl Let bij de inbouw op de correcte positionering van de reflector (Wallwasher, **SNS... Q/R C03 WW...**).



SONNOS



- de Optimale Montagepositionen für **SNS...WW**
- en Optimum mounting locations for **SNS...WW**
- fr Positions de montage optimales pour **SNS...WW**
- it Posizioni di montaggio ottimali per **SNS...WW**
- es Posiciones de montaje óptimas para **SNS...WW**
- nl Optimale montageposities voor **SNS...WW**

\* min.  $1/3 X$   
max.  $(1/3 X) \times 1,5$

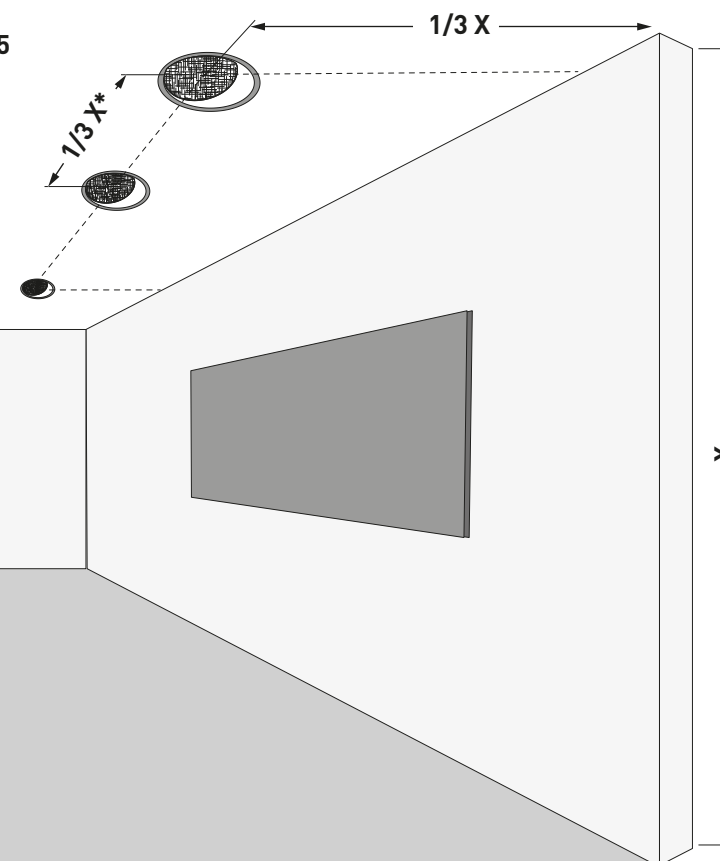



SONNOS

- de Montage
- en Mounting
- fr Montage
- it Montaggio
- es Montaje
- nl Montage

Type  
 SNS ... R C01... R ...  
 SNS ... R C03 ... R ...

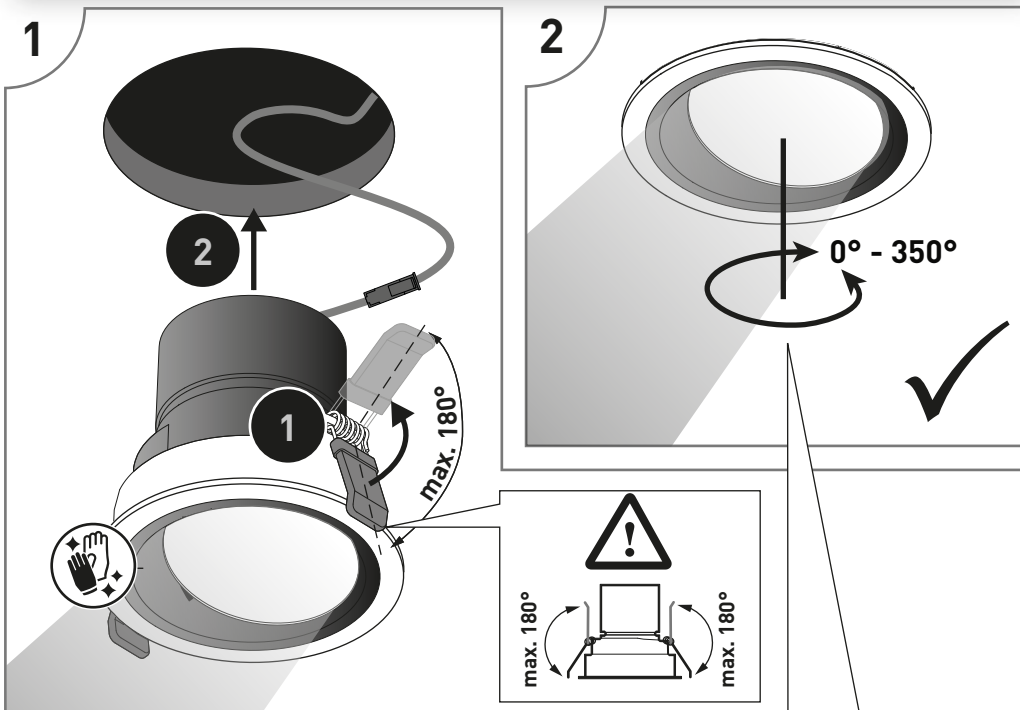

- de Überprüfen Sie die Drehbarkeit des Reflektors mit dem Konnektor (0° - 350°, SNS... R C01/03... R... ).
- en Check the rotatability of the reflector with the connector (0° - 350°, SNS... R C01/03... R... ).
- fr Vérifiez la plage de rotation du réflecteur avec le connecteur monté (0 °à 350 °, SNS... R C01/03... R... ).
- it Verificare la rotabilità del riflettore con il connettore (0° - 350°, SNS... R C01/03... R... ).
- es Compruebe la rotabilidad del reflector con el conector (0° - 350°, SNS... R C01/03... R... ).
- nl Controleer of de reflector gedraaid kan worden met de connector (0° - 350°, SNS... R C01/03... R... ).



SONNOS

- de Montage
- en Mounting
- fr Montage
- it Montaggio
- es Montaje
- nl Montage

Type  
 SNS ...Q C ... IP54  
 SNS ...R C ... IP54

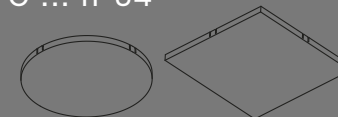

- de Beachten Sie die Montageschritte auf den Seiten 22 und 23, 26 und 27.
- en Observe the mounting steps on pages 22 and 23, 26 and 27.
- fr Respectez les étapes de montage des pages 22 et 23, 26 et 27.
- it Osservare la sequenza di montaggio alle pagine 22 e 23, 26 e 27.
- es Tenga en cuenta los pasos de montaje indicados en las páginas 22 y 23, 26 y 27.
- nl Neem de montageschappen op pagina's 22 en 23, 26 en 27 in acht.



IP54

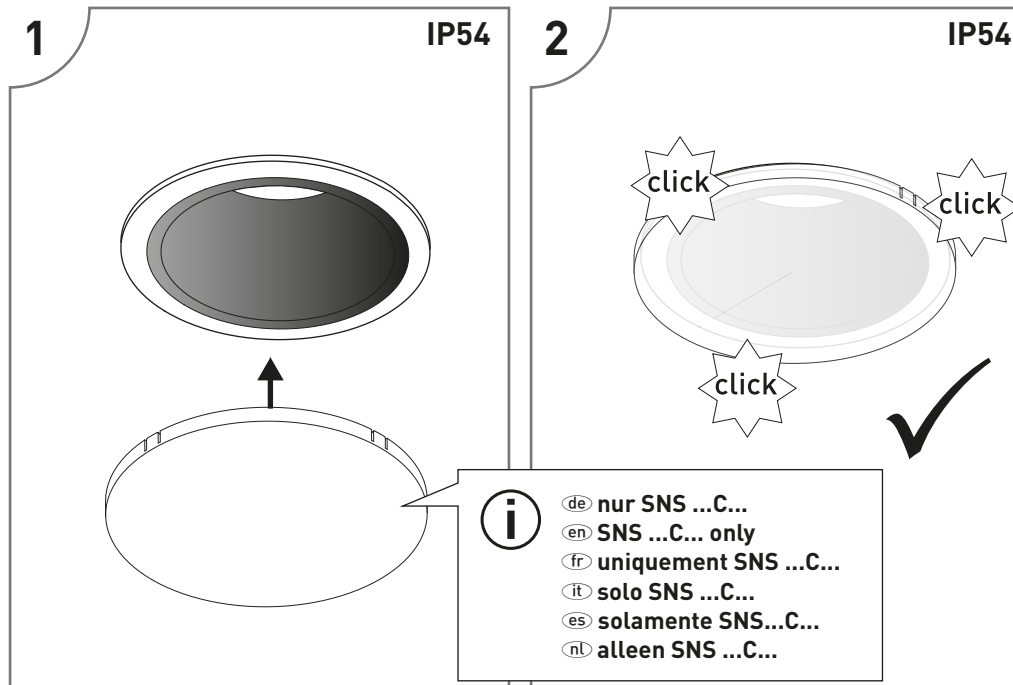

- de nur SNS ...C...
- en SNS ...C... only
- fr uniquement SNS ...C...
- it solo SNS ...C...
- es solamente SNS...C...
- nl alleen SNS ...C...



SONNOS

- de Demontage
- en Disassembly
- fr Démontage
- it Smontaggio
- es Desmontaje
- nl Demontage

Type  
 SNS ... Q T01 ...  
 SNS ... Q T03 ...  
 SNS ... R T01 ...  
 SNS ... R T03 ...

Type  
 SNS ZDT RC 2  
 TOC  
 75 723 00

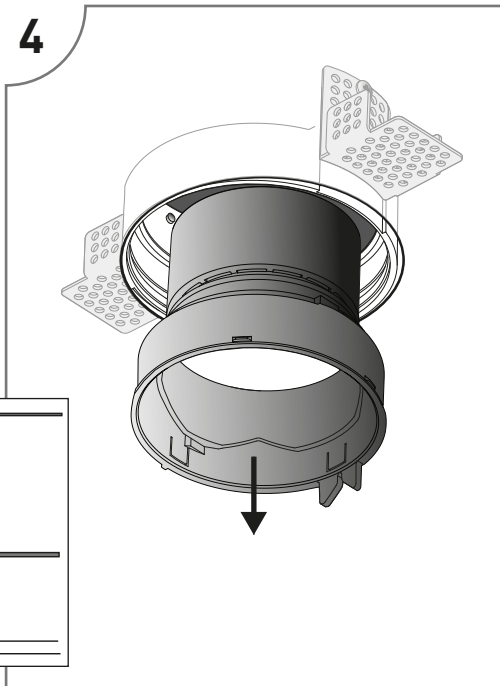
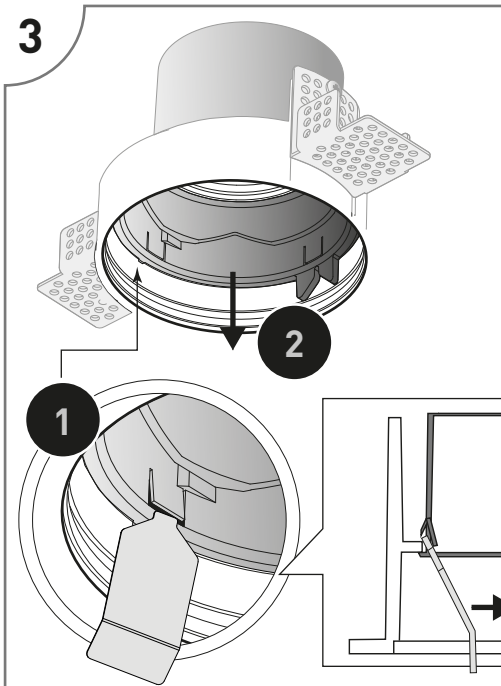
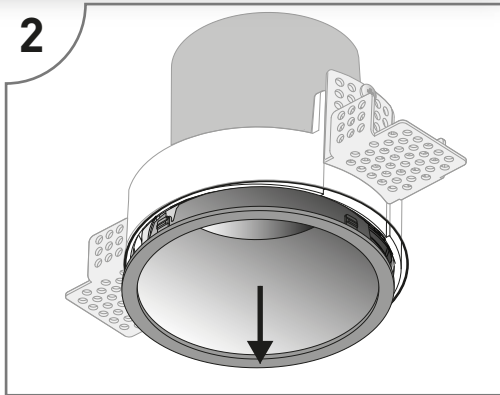
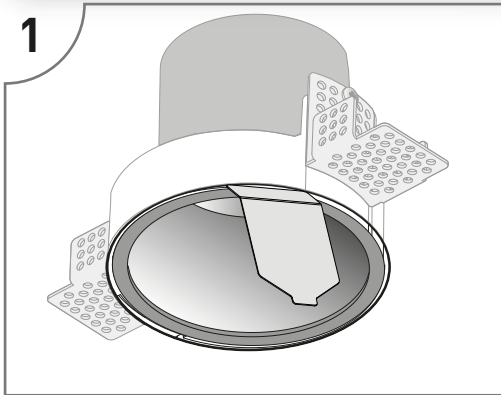

SONNOS

- de Demontage
- en Disassembly
- fr Démontage
- it Smontaggio
- es Desmontaje
- nl Demontage

Type  
 SNS ... Q C01 ...  
 SNS ... Q C03 ...  
 SNS ... R C01 ...  
 SNS ... R C03 ...

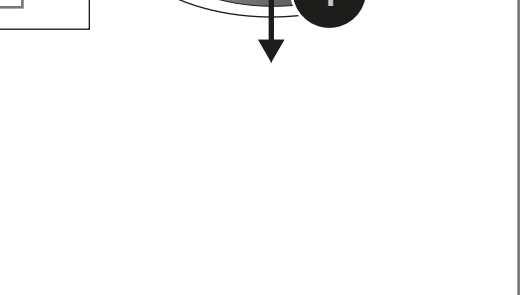
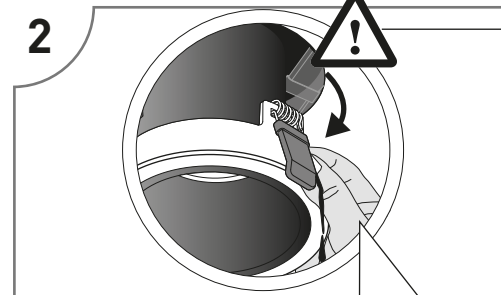
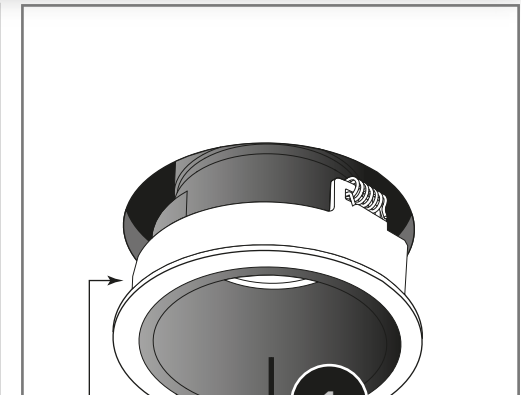
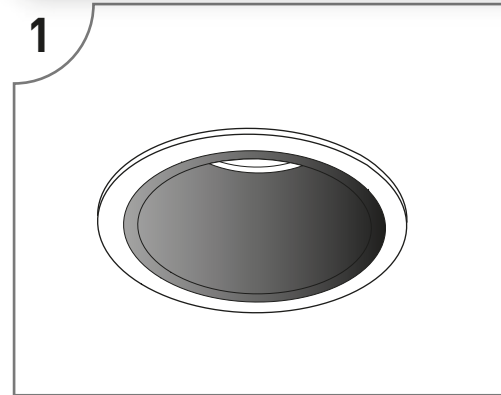

- de Bei Demontage die Position der Federn beachten,  
**Achtung-Klemmgefahr!**
- en Observe the position of the springs when disassembling,  
**Note, risk of trapping!**
- fr Lors du démontage, respecter la position des ressorts,  
**Attention, risque de pincement!**
- it Durante la fase di smontaggio fare attenzione alla posizione delle molle,  
**Attenzione: pericolo di incastro!**
- es Durante el desmontaje, preste atención a la posición de los muelles:  
**¡Atención! ¡Peligro de atrapamiento!**
- nl De positie van de veren in acht nemen bij de demontage,  
**Opgelet – knelgevaar!**





TRILUX GmbH & Co. KG

Heidestraße  
D-59759 Arnsberg  
+49 2932 301-0  
info@trilux.de  
www.trilux.com